

Technical Product Manual

VDO cockpit vision VDO cockpit international

6. Electric Pressure Gauge (dia. 52 mm)

6.2 Technical Data

Operating voltage:	11 ... 16 V or 21.5 ... 30 V
Movement:	System Ke (90°)
Current consumption:	82 mA (without illumination)
Operating temp.:	- 30°C ... + 85°C
Storage temperature:	- 40°C ... + 90°C
Illumination:	1 light bulb 14 V, 3.4 W or 24 V, 3 W
Protection:	IP64 DIN40 050 from the front reverse-polarity protection
Vibration resistance:	max. 1g eff., 25 ... 2000 Hz, duration 8h, f. 1 octave/min.
Nominal position:	NL 0 to NL 90, DIN 16257

VDO cockpit international
dia. 52 mm Floodlight



Mounting hole: dia. 53mm

Sensor:
pressure sensor (diaphragm),
not included.

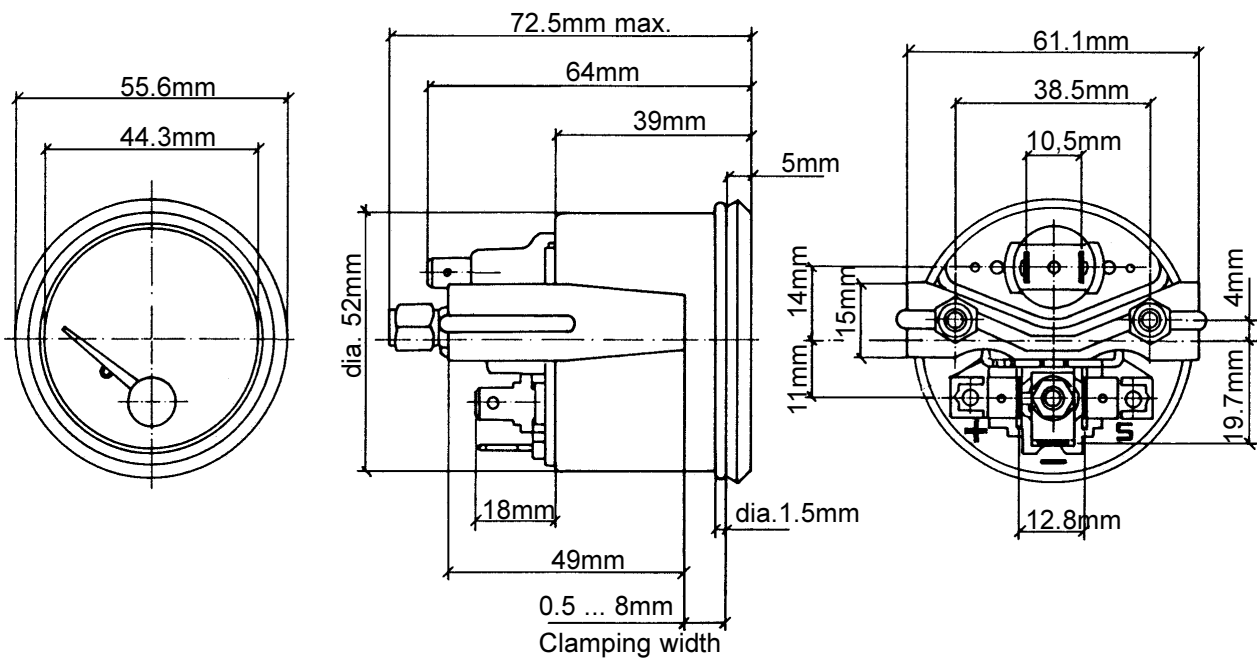

Pin assignment:

Pin +: + 12 V or + 24 V,
terminal 15

Pin -: Ground, terminal 31

Pin S: Sensor

Technical Product Manual

VDO cockpit vision VDO cockpit international

6. Electric Pressure Gauge (dia. 52 mm)

6.3 Pressure Sensors

The pressure sensors needed to operate the instrument is not included with the instrument.

The following pressure sensors (see data sheets for sensors) adapted to the instrument indicating range, can be used:

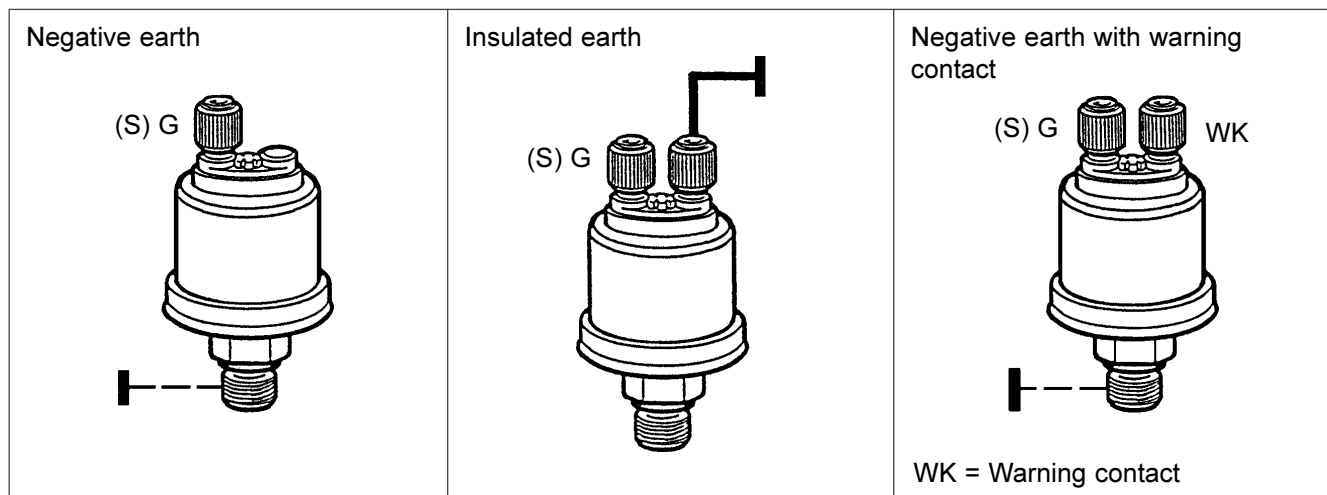

The sensor is installed in the oil circuit at a position specified by the vehicle manufacturer (e.g. oil pressure switch). Use an adequate parts kit if a direct installation is not possible at this location.

To mount the pressure sensor it is absolutely only to use the hexagon nut.

If the connection thread is cylindrical, a sealing washer or a sealing ring made of copper must be fitted.

The values mentioned in the following table for the maximum tightening torque (Nm max.) refer exclusively to the load-bearing capacity of pressure sensors.

 Prior to using the pressure sensor, it is important to ask the manufacturer of the vehicle, equipment system or engine in each instance for the maximum torque [? Nm max.] value for the threaded hole into which the pressure sensor is to be screwed. Non-observance of the maximum thightening torque specified for the threaded hole in each instance can result in damage to the vehicle, engine or equipment system.

Thread	max.
M 10 x 1	30 Nm
1/8 in. BSPF	30 Nm
1/8 - 27 NPTF	30 Nm
R 1/8 DIN 2999	30 Nm
M12 x 1.5	40 Nm
M12 x 1	50 Nm
M14 x 1.5	60 Nm
1/4 in. BSPF	60 Nm
1/4 - 18 NPTF	60 Nm
3/8 - 18 NPTF	60 Nm
M 16 x 1.5	80 Nm
3/8 - 18 Dryseal NPTF	80 Nm
M 18 x 1.5	100 Nm

Technical Product Manual

VDO cockpit vision VDO cockpit international

6. Electric Pressure Gauge (dia. 52 mm)

6.4 Wiring Diagrams

Pressure sensor:

negative earth
or
insulated earth

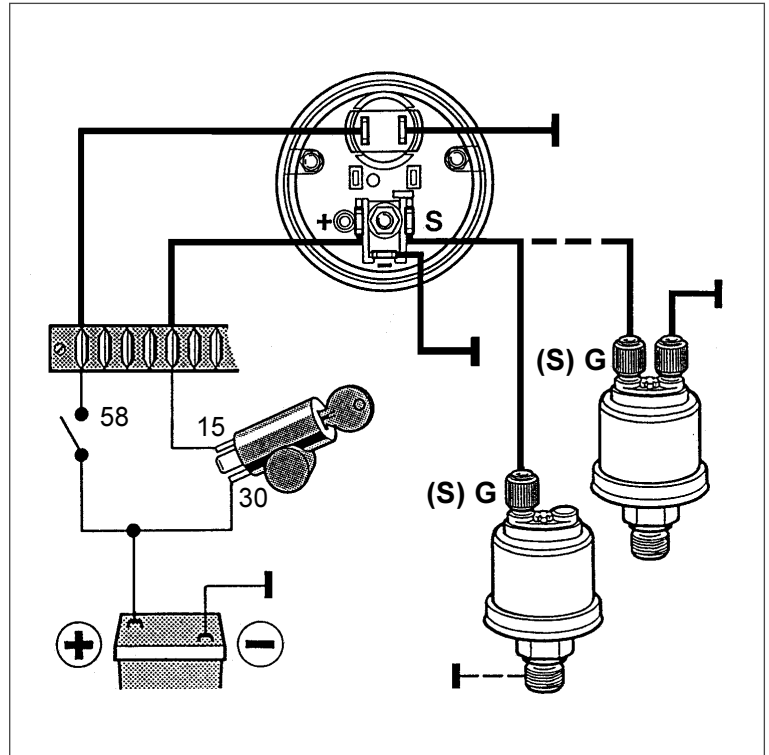

Pressure sensor with warning contact:

negative earth

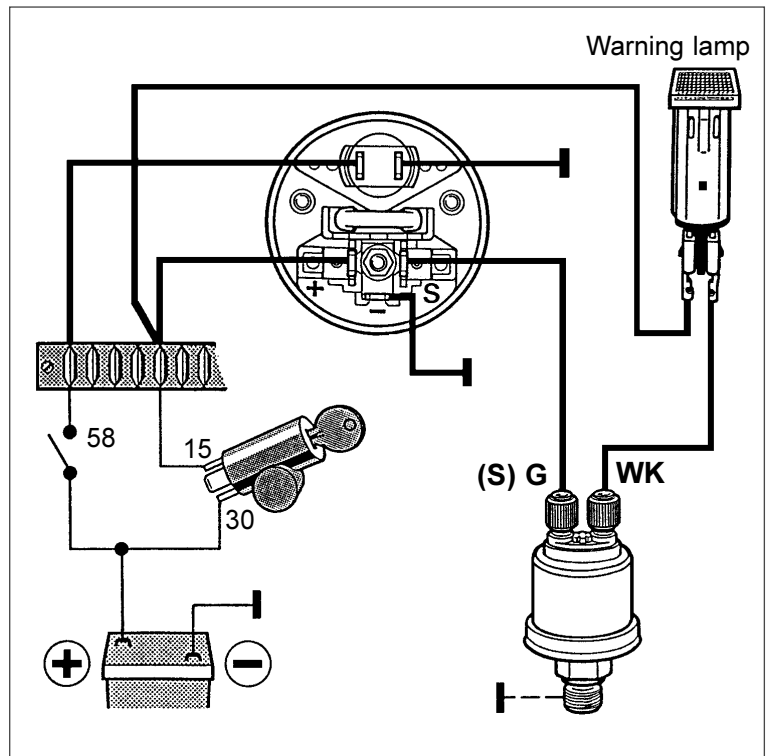

WK = Warning contact

Technical Product Manual

VDO cockpit vision VDO cockpit international

6. Electric Pressure Gauge (dia. 52 mm)

6.5 Testing Instructions

Test accessories

1x Power supply	} contained in test cables kit X12-019-101-001
1x Test cable No. 3	
1x Measuring cable	
1x Resistor decade	

Pin allocation

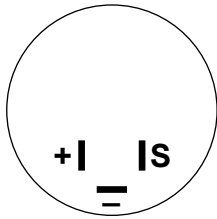

Pin + + 12V or + 24V
Pin - Ground
Pin S Sensor signal input

Test circuit diagram

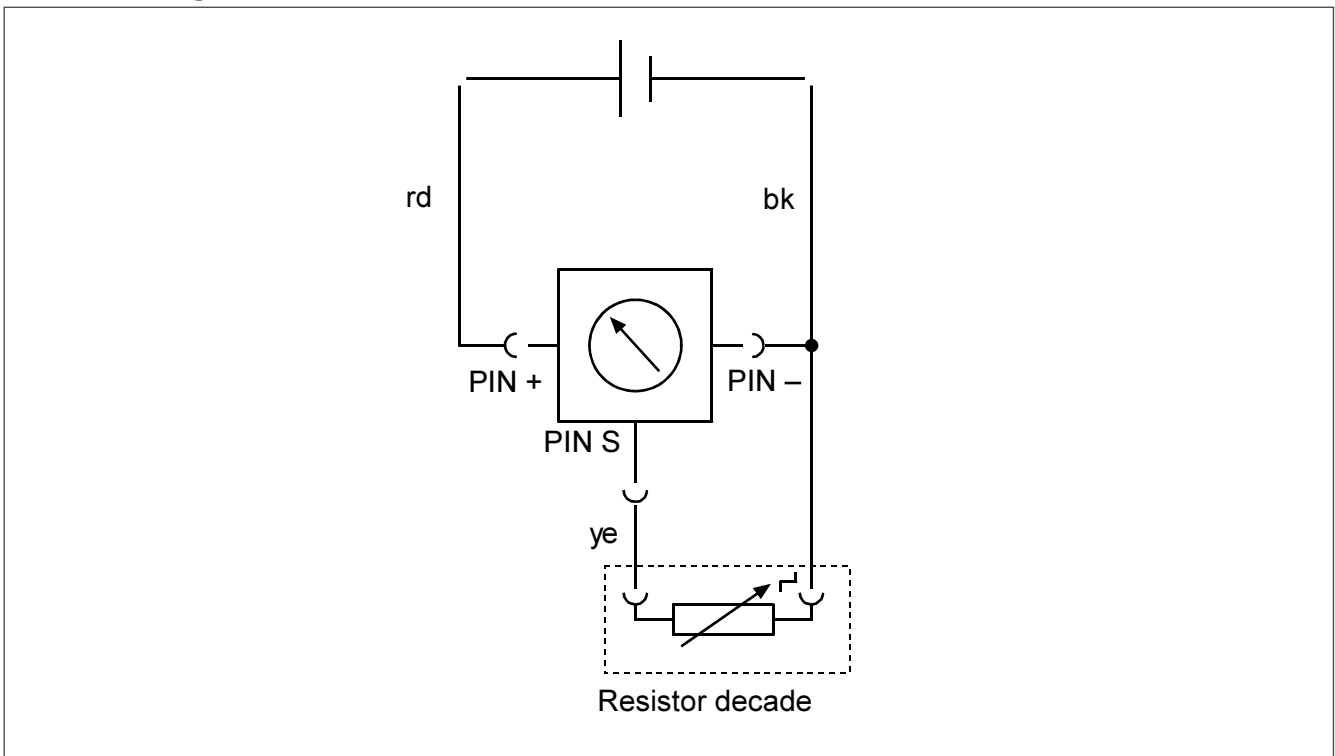

Test method description

Basic settings:	12 V instruments	»»»»»	14 V
	24 V instruments	»»»»»	28 V

Start the pointer position test with the highest resistance value!

Technical Product Manual

VDO cockpit vision VDO cockpit international

6. Electric Pressure Gauge (dia. 52 mm)

6.5 Testing Instructions

Test of the movement

Connect the instrument as shown in the test circuit diagram, using test cable 3.

The indication can be tested with the resistor decade 'sensor simulator'.

The pointer moves to full scale deflection if the resistor decade is not connected.

The following tables shows the resistance values and the indication in angular degrees.

0 to 2 bar

Indication (bar)	0	1	2
Resistance (Ω)	10	99	184
Deflection ($^\circ\angle$)	0	41.4	87.4

0 to 5 bar

Indication (bar)	0	0.5	1	1.5	2	2.5	3	3.5	4	4.5	5
Resistance (Ω)	10	30	48	65	82	99	116	134	151	168	184
Deflection ($^\circ\angle$)	0	6.4	13.4	21.3	30.6	41.4	53	64.6	74.2	81.6	87.4

0 to 10 bar

Indication (bar)	0	1	2	3	4	5	6	7	8	9	10
Resistance (Ω)	10	31	52	71	88	106	124	140	155	170	184
Deflection ($^\circ\angle$)	0	6.8	15.2	24.4	34.3	46.2	58.3	68.2	76.1	82.4	87.4

0 to 25 bar

Indication (bar)	0	2.5	5	7.5	10	12.5	15	17.5	20	22.5	25
Resistance (Ω)	10	32	53	73	92	109.1	125	143	155	169	184
Deflection ($^\circ\angle$)	0	7.1	15.6	25.5	36.8	42.7	58.9	69.9	76.1	82	87.4

Technical Product Manual





VDO cockpit vision VDO cockpit international

6. Electric Pressure Gauge (dia. 52 mm)

6.6 Instruments Survey

VDO cockpit vision (Backlight) dia. 52 mm

Part No. 350-010-...

Dial		Special feature	Part No.
Range	Imprint		
0 ... 5 bar	bar 	Clamp ring 12 V	008K
0 ... 5 bar	bar 	Stud bolts 12 V	014K
0 ... 10 bar	bar 	Clamp ring 12 V	007K
0 ... 10 bar	bar 	Stud bolts 12 V	015K
0 ... 150 PSI 0 ... 10 bar	PSI, bar 	Dual scale, clamp ring 12V without colour caps	019C

VDO cockpit vision (Backlight) dia. 52 mm

Part No. 350-020-...

Dial		Special feature	Part No.
Range	Imprint		
0 ... 10 bar	bar 	Clamp ring 24 V without colour caps	001C

Technical Product Manual







VDO cockpit vision VDO cockpit international

6. Electric Pressure Gauge (dia. 52 mm)

6.6 Instruments Survey











VDO cockpit international (Floodlight) dia. 52 mm

Part No. 350-030-...

Dial		Special feature	Part No.
Range	Imprint		
0 ... 5 bar	bar 	12 V	003C 003G
0 ... 10 bar	bar 	12 V	004C 004G
0 ... 25 bar	bar 	12 V	005C 005G
0 ... 10 bar	bar 	12 V	011C 011G
0 ... 5 x 100 kPa	kPa x 100 	12 V	016C
0 ... 10 x 100 kPa	kPa x 100 	12 V	017C
0 ... 80 psi 0 ... 5 bar	psi, bar 	12 V Dual scale	020C

VDO cockpit international (Floodlight) dia. 52 mm

Part No. 350-040-...

Dial		Special feature	Part No.
Range	Imprint		
0 ... 2 bar	bar 	24 V	001C
0 ... 5 bar	bar 	24 V	003C 003G
0 ... 10 bar	bar 	24 V	004C 004G
0 ... 25 bar	bar 	24 V	005C 005G
0 ... 10 bar	bar 	24 V	011C 011G
0 ... 5 x 100 kPa	kPa x 100 	24 V	016C
0 ... 10 x 100 kPa	kPa x 100 	24 V	017C
0 ... 80 psi 0 ... 5 bar	psi, bar 	24 V Dual scale	020C
0 ... 10 bar 0 ... 150 psi	bar, psi 	24 V Dual scale	015C
0 ... 400 psi 0 ... 25 bar	psi, bar 	24 V Dual scale	029C 029G
0 ... 5 bar	bar 	24 V	023C