



**SIDE-POWER**  
Thruster Systems

**DC SE & SE-IP SERIES**

# **OPERATIONAL THRUSTER USER MANUAL**

**Keep this  
manual onboard!**



To download your language go to [www.side-power.com](http://www.side-power.com)



**SLEIPNER MOTOR AS**

P.O. Box 519  
N-1612 Fredrikstad  
Norway  
[www.side-power.com](http://www.side-power.com)

**Document id: 5915**

**Revision: 9**

**Date: 2020**



Made in Norway

© Sleipner Motor AS 2020

**Important User Considerations and Precautions** ..... 3**User Manual**

Thruster Operation .....	4
Control Panel.....	5
Maintenance .....	6 - 8
Troubleshooting.....	9
Checklist.....	10
Spare Parts.....	11

**Products**

SE300/300TC - SE300 Tunnel thruster, 48V  
 SE250/300TC - SE250 Tunnel thruster, 24V  
 SE210/250TC - SE210 Tunnel thruster, 24V  
 SE170/250TC-AM - Sidepower SE170-TC-Amel 24V  
 SE170/250TC-AMS - Sidepower S-link SE170-TC-Amel  
 SE170/250TC-AMR - Sidepower SE170-TC-Amel Retrac  
 SE170/250TC - SE170 Tunnel thruster, 24V  
 SE150/215T-24V - SE150 Tunnel thruster, 24V  
 SE150/215T-24 - SE150 Tunnel thruster, 24V  
 SE130/250T-12V - SE130 Tunnel thruster, 12V  
 SE130/250T-24V - SE130 Tunnel thruster, 24V  
 SE120/215T-24V - SE120 Tunnel thruster, 24V  
 SE120/215T-24 - SE120 Tunnel thruster, 24V  
 SE100/185T-24V - SE100 Tunnel thruster, 24V  
 SE100/185T-12V - SE100 Tunnel thruster, 12V  
 SE80/185T-12V - SE80 Tunnel thruster, 12V  
 SE80/185T-24V - SE80 Tunnel thruster, 24V  
 SE60/185S-24V - SE60 Tunnel thruster, 24V  
 SE60/185S-12V - SE60 Tunnel thruster, 12V  
 SE60/185S2-12V - SE60 Tunnel thruster, 12V  
 SE60/185-12V OST - SE60 Tunnel thruster, 12V  
 SE60/185S2-24V - SE60 Tunnel thruster, 24V  
 SE50/140S-12V - SE50 Tunnel thruster, 12V  
 SE50/140S-24V - SE50 Tunnel thruster, 24V  
 SE40/140S-ALU - SE40 Tunnel thruster, 12V  
 SE40/140 SPESIAL - SE40 Tunnel thruster, 12V  
 SE40/125S2 - SE40 Tunnel thruster, 12V  
 SE40/140S - SE40 Tunnel thruster, 12V  
 SE40/125S - SE40 Tunnel thruster, 12V  
 SE30/140S - SE30 Tunnel thruster, 12V  
 SE30/125S - SE30 Tunnel thruster, 12V  
 SE30/125S2 - SE30 Tunnel thruster, 12V  
 SE25/110S - SE25 Tunnel thruster, 12V  
 SE20/110S - SE20 Tunnel thruster, 12V  
 SE170/250TC-IP - SE170 Tunnel thruster, 24V-IP  
 SE130/250T-12IP - SE130 Tunnel thruster, 12V-IP  
 SE130/250T-24V - SE130 Tunnel thruster, 24V  
 SE130/250T-24IP - SE130 Tunnel thruster, 24V-IP  
 SE120/215T-24IP - SE120 Tunnel thruster, 24V-IP  
 SE100/185T-12IP - SE100 Tunnel thruster, 12V-IP  
 SE100/185T-24IP - SE100 Tunnel thruster, 24V-IP  
 SE80/185T-12IP - SE80 Tunnel thruster, 12V-IP  
 SE80/185T-24IP - SE80 Tunnel thruster, 24V-IP  
 SE60/185S-24V - SE60 Tunnel thruster, 24V  
 SE60/185S2-12IP - SE60 Tunnel thruster, 12V-IP  
 SE60/185S-24IP - SE60 Tunnel thruster, 24V-IP  
 SE60/185S-12IP - SE60 Tunnel thruster, 12V-IP  
 SE50/140S-24IP - SE50 Tunnel thruster, 24V-IP  
 SE50/140S-12IP - SE50 Tunnel thruster, 12V-IP  
 SE40/125S2-12IP - SE40 Tunnel thruster, 12V-IP  
 SE40/125S-12IP - SE40 Tunnel thruster, 12V-IP  
 SE30/125S2-12IP - SE30 Tunnel thruster, 12V-IP  
 SE30/125S-12IP - SE30 Tunnel thruster, 12V-IP  
 SE60/185S2-24IP - SE60 Tunnel thruster, 24V-IP  
 SE60/185S2-24V - SE60 Tunnel thruster, 24V

**DECLARATION OF CONFORMITY**

MC\_0020



Sleipner Motor AS  
 P.O. Box 519, Arne Svendsensgt. 6-8  
 N-1612 Fredrikstad, Norway

Declare that this product with accompanying standard control systems complies with the essential health and safety requirements according to:

DIRECTIVE 2013/53/EU  
 DIRECTIVE 2014/30/EU  
 DIRECTIVE 2014/35/EU

**IMPORTANT**

**Failure to follow the Considerations and precautions can cause serious injury / damage and will render all warranty given by Sleipner Motor AS VOID.**

**Never use thrusters when close to objects/ persons or pets in the water. The thruster will draw objects into the tunnel and the rotating propellers. This will cause serious injuries and damage the thruster.**

**Always turn the main power switch off before touching any part of the thruster, An incidental start while touching moving parts can cause serious injuries.**

**Never store items (e.g. equipment, sails, ropes etc.) in the same compartment as the thruster. When the thruster runs for an extended period, it can reach 150°C and will cause damage to nearby items or cause a fire. The electromotor will generate some carbon dust so any storage compartment must be separated from the thruster to prevent nearby items from becoming dusty/ dirty.**

**Any loose items near the thruster motor can cause problems with electrical wiring coming loose and short-circuiting.**

- Ensure you know the location of the main battery switch that disconnects the thruster from all power sources (batteries) so the thruster can be turned off in case of serious malfunction.
- Always turn the control device off when the thruster is not in use or when leaving the boat.
- When leaving the boat always turn off the main power switch for the thruster.
- The maximum continuous run time of the electrical thruster is approximately 3 minutes. The motor is equipped with a built-in thermal cut-off switch that will shut the motor off when overheating. Consider this when planning your manoeuvring.
- Never use thrusters out of water.
- If the thruster stops giving thrust while running, there is possibly a problem in the drive system. You must immediately stop running the thruster and turn it off. Running the thruster for more than a few seconds without resistance from the propeller can cause serious damage to the thruster.
- We advise keeping the main engine(s) running while using the thruster. This will keep the batteries in a good charge condition. It will also give better performance to the thruster.
- If the performance of the thruster is reduced check the battery system or check the tunnel for marine growth.
- If two panels are operated with conflicting directions at the same time the thruster will not run. If both are operated in the same direction, the thruster will run in this direction.
- If you notice any faults with the thruster switch it off to avoid further damage.
- The electro motor, its components, contacts/ plugs or other joints in the control cables must be mounted so they will remain dry at all times.
- It is the owner/ captain/ other responsible parties full responsibility to assess the risk of any unexpected incidents on the vessel. If the thruster stops giving thrust for some reason while manoeuvring you must have considered a plan on how to avoid damage to persons or other objects.
- The primary purpose of the thruster is to manoeuvre/ dock the vessel. Forward/ reverse speed must not exceed 4 knots when operated.

**IMPORTANT**

**NEVER Disassemble any part of the Ignition Protected assembly. Tampering with the Ignition Protected assembly will cause it to lose this safety feature.**

**If there is a problem with your Ignition Protected stern thruster, please contact your dealer.**

**! Please refer to the graphic for special considerations relating to your model !**

Take time to practice operation in open water to become familiar with the thruster and to avoid damages to your boat or people.

#### How to use the Thruster

1. Turn on the main power switch for the thruster. **(NB: Always turn off the main power switch when not on-board.)**
2. Turn on the control panel by pushing both "ON" buttons on the Side-Power panel simultaneously.  
\* Turn off the control panel by pushing the "OFF" button

#### Joystick Control

To Turn the bow in the desired direction move the joystick in the direction you wish the bow to move.

#### Button Control

To Turn the bow in the desired direction push the red button for port movement or the green button for starboard.

\* For other controls like foot switches or toggle-switches please refer to that products user manual for detailed operational use.

#### How to use a combined bow and stern thruster

The combination of a bow and stern thruster offers total manoeuvrability to the boat and the ability to move the bow and the stern separately from each other. This enables you to move the boat sideways in both directions and turn the boat around its axis 360° staying stationary.

**NB: At speed the side thruster will have little or no effect to steer the vessel.**

#### ON/ OFF CONTROL PANEL



#### REMOTE CONTROL



# Control Panel



Turn ON thruster



Turn OFF thruster

\*Control panel example

Activating the bow thruster



\*Control panel example



Activating the stern thruster



\*Control panel example

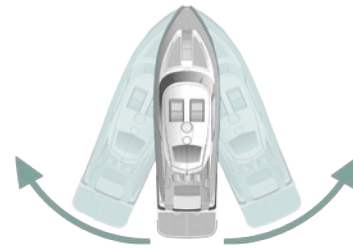

Activating both bow and stern thruster to push the boat sideways



\*Control panel example

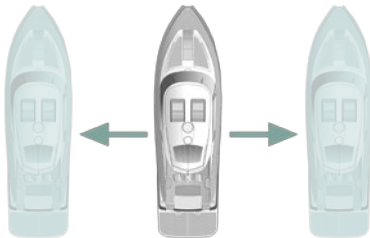

Activating both bow and stern thruster to rotate the boat on axis



\*Control panel example

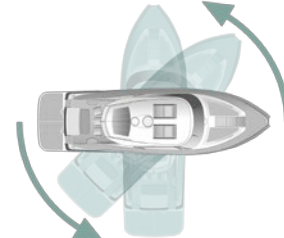

As a part of the seasonal service of your Thruster before every season, always check that:

#### In Water

- The area around the thruster inside the boat is clean and dry. Ensure there are no signs of water leaks.
- All electrical connections are clean and fastened firmly.
- Ensure that your batteries are in good condition.

#### Out of Water

- Check the propeller(s) or tunnel for any damage for example impact damage.
- The propeller(s) is fastened securely to the gear leg.
- Check all components of thruster are fastened securely.
- Clean the tunnel and gear leg from marine growth.
- Paint the propeller and gear leg with anti-fouling before every season to keep it clean from sea growth. **(NB: Never paint the anode, sealing or propeller shaft. Ensure paint does not enter the space between the propeller and the gear leg.)**
- Change the anode before every season, or when half the anode has eroded. Always use a sealant or thread glue on the holding screw to ensure that it does not fall off.
- Check the gear leg is not leaking oil

#### IMPORTANT

**NEVER Disassemble any part of the Ignition Protected assembly. Tampering with the Ignition Protected assembly will cause it to lose this safety feature.**

**If there is a problem with your Ignition Protected stern thruster, please contact your dealer.**

SE / SEP  
\*20  
\*25  
\*30  
\*40

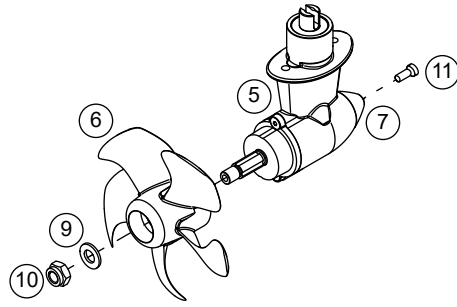

SE / SEP  
\*50

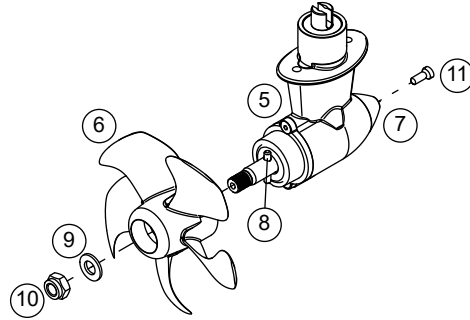

SE / SEP  
\*60

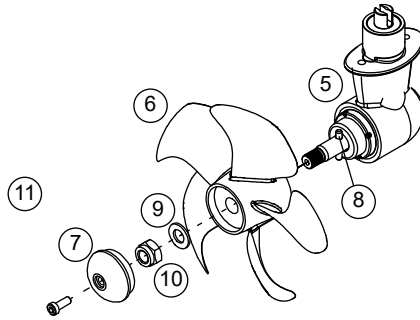

SE / SEP  
\*80  
\*100  
\*120  
\*130  
\*150  
\*170  
\*210

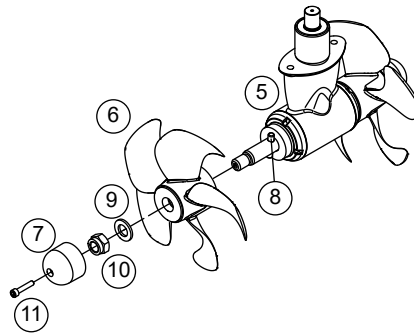

SE / SEP  
\*250  
\*300

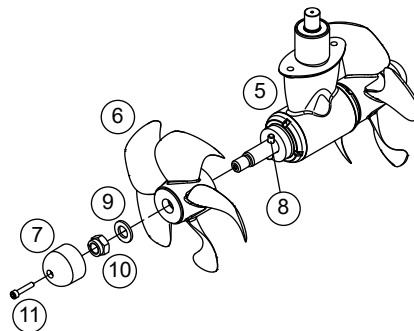
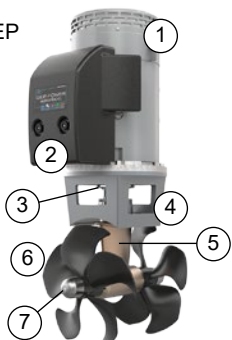

KEY:

- 1. Electro motor
- 2. Directional Solenoids/ power & control cables
- 3. Coupling (inside motor bracket)
- 4. Motor Bracket
- 5. Gear Leg
- 6. Propeller
- 7. Anode
- 8. Propeller Drive pin
- 9. Washer
- 10. Lock Nut
- 11. Fastening Screw for anode



SE / SEP (IP)  
\*30  
\*40

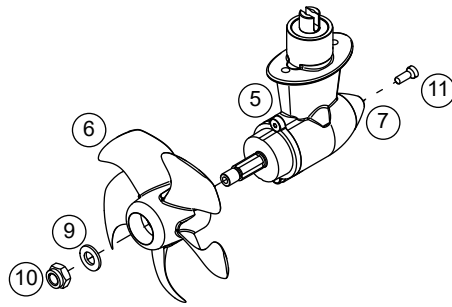

SE / SEP (IP)  
\*50

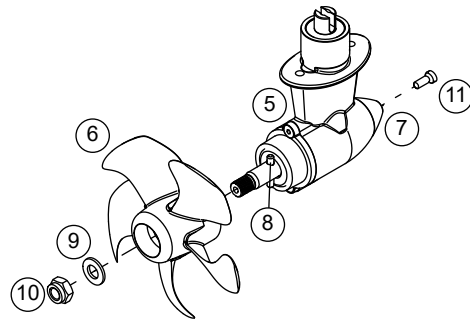

SE / SEP (IP)  
\*60

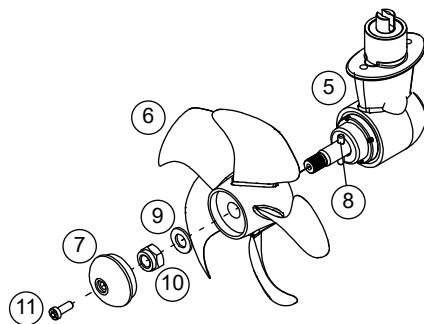

SE / SEP (IP)  
\*80  
\*100  
\*120  
\*130  
\*170

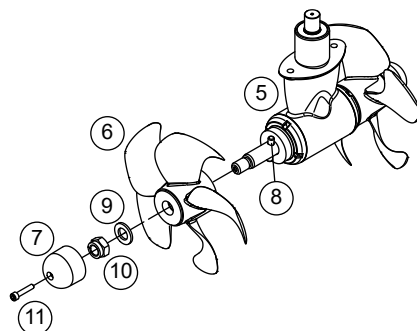

KEY:

- 1. Electro motor
- 2. Directional Solenoids/ power & control cables
- 3. Coupling (inside motor bracket)
- 4. Motor Bracket
- 5. Gear Leg
- 6. Propeller
- 7. Anode
- 8. Propeller Drive pin
- 9. Washer
- 10. Lock Nut
- 11. Fastening Screw for anode



Before seeking assistance from the website help desk from your Side-Power dealer/ distributor, please perform these tests.  
**(NB: If you are unable to understand what to check, you must consult a Side Power distributor.)**

CHECK	SOLUTION
<b>The motor runs, but there is no thrust</b>	
Check propellers are fitted, fastened correctly and not damaged on the prop shaft.	Re-fasten or replace if necessary
* Check the flexible coupling between the motor and drive shaft is fitted correctly and not damaged.	Replace if necessary
* Check the gear box is not damaged.	Replace if necessary
<b>The thrusters performance is reduced</b>	
Check the propeller, gear house and tunnel are free from growth/ barnacles or debris and damage.	If there is growth in the tunnel, this will disturb/ block the water flow and significantly reduce performance
Check the battery is in a good working condition.	<p><b>(NB: Keep the main engine(s) running in use to have a continuous charge to the batteries)</b></p> <ul style="list-style-type: none"> <li>• Check batteries are not worn out or in a bad charged condition</li> <li>• Check electrical connections/ wiring for damage or wear (corrosion)</li> <li>• Check cables are the correct size per the product manual</li> <li>• Tighten/ re-adjust connections</li> </ul>
<b>The thruster does not start/ works in only one direction or does not turn off</b>	
Check the main switch is active/ on.	Switch the main switch open if it is closed.
Check all battery fuses are in good condition.	<ul style="list-style-type: none"> <li>• Check batteries</li> <li>• Check electrical connections/ wiring for damage or wear (corrosion)</li> <li>• Tighten/ re-adjust and clean connections</li> </ul>
The thruster is not shutting off after the Joy Stick/ panel is disengaged.	Hit the main switch to disengage the thruster. Contact and consult a Side Power distributor as the control system has been damaged.
<b>The thruster works in only one direction</b>	
Damaged relay.	Hit the main switch to disengage the thruster. Contact and consult a Side Power distributor as the control system has been damaged.
<b>The thruster runs in a pulsing action</b>	
This is a build-in error response. -Solenoids failure	Hit the main switch to disengage the thruster. Contact and consult a Side Power distributor.
The solenoid might be in a lock-in/ auto stop position.	Hit the main switch to disengage the thruster. Contact and consult a Side Power distributor.

\* Not applicable to SX thrusters.

CHECK TO PERFORM	DATE											
The propeller is fastened securely to the gear leg.												
The thruster components are fastened securely.												
The area around the thruster is clean and dry. If there are signs of water, try to find the source and eliminate it.												
Apply the propeller and gear leg with anti-fouling.												
Batteries are in good condition.												
All electrical connections are clean and fastened firmly.												
Replace the anode.												

**For the most up to date documentation, we advise you to visit our website [www.side-power.com](http://www.side-power.com) for the spare parts list.**

**For additional supporting documentation, we advise you to visit our website [www.side-power.com](http://www.side-power.com) for the spare parts list.**

1. The equipment manufactured by Sleipner Motor AS (The "Warrantor") is warranted to be free from defects in workmanship and materials under normal use and service.
2. This Warranty is in effect for of two years (Leisure Use) or one year (Commercial use) from the date of purchase by the user. Proof of purchase must be included, to establish that it is inside the warranty period.
3. This Warranty is transferable and covers the product for the specified time period.
4. In case any part of the equipment proves to be defective, other than those parts excluded in paragraph 5 below, the owner should do the following:
  - (a) Prepare a detailed written statement of the nature and circumstances of the defect, to the best of the Owner's knowledge, including the date of purchase, the place of purchase, the name and address of the installer, and the Purchaser's name, address and telephone number;
  - (b) The Owner should return the defective part or unit along with the statement referenced in the preceding paragraph to the warrantor, Sleipner Motor AS or an authorized Service Centre, postage/shipping prepaid and at the expense of the Purchaser;
  - (c) If upon the Warrantor's or Authorized Service Centre's examination, the defect is determined to result from defective material or workmanship, the equipment will be repaired or replaced at the Warrantor's option without charge, and returned to the Purchaser at the Warrantor's expense;
  - (d) no refund of the purchase price will be granted to the Purchaser, unless the Warrantor is unable to remedy the defect after having a reasonable number of opportunities to do so. Prior to refund of the purchase price, Purchaser must submit a statement in writing from a professional boating equipment supplier that the installation instructions of the Installation and Operation Manual have been complied with and that the defect remains;
  - (e) warranty service shall be performed only by the Warrantor, or an authorized Service Centre, and any attempt to remedy the defect by anyone else shall render this warranty void.
5. There shall be no warranty for defects or damages caused by faulty installation or hook-up, abuse or misuse of the equipment including exposure to excessive heat, salt or fresh water spray, or water immersion except for equipment specifically designed as waterproof.
6. No other express warranty is hereby given and there are no warranties which extend beyond those described in section 4 above. This Warranty is expressly in lieu of any other expressed or implied warranties, including any implied warranty of merchantability, fitness for the ordinary purposes for which such goods are used, or fitness for a particular purpose, and any other obligations on the part of the Warrantor or its employees and representatives.
7. There shall be no responsibility or liability whatsoever on the part of the Warrantor or its employees and representatives for injury to any person or persons, or damage to property, loss of income or profit, or any other consequential or resulting damage or cost which may be claimed to have been incurred through the use or sale of the equipment, including any possible failure or malfunction of the equipment, or part thereof.
8. The Warrantor assumes no liability for incidental or consequential damages of any kind including damages arising from collision with other vessels or objects.
9. This warranty gives you specific legal rights, and you may also have other rights which vary from country to country.

# Worldwide sales and service



[www.side-power.com](http://www.side-power.com)



SLEIPNER MOTOR \* AS P.O. Box 519 \* N-1612 Fredrikstad \* Norway

The information given in the document was correct at the time it was published. However, Sleipner Motor AS can not accept liability for any inaccuracies or omissions it may contain. Continuous product improvement may change the product specifications without notice. Therefore, Sleipner Motor AS can not accept liability for any possible differences between product and document.

MC\_0030