

Keep this
manual onboard!



User Manual

Including Installation For Voltage Conversion Unit
SE120, SE130, SE150, SE170



SLEIPNER GROUP

P.O. Box 519
N-1612 Fredrikstad
Norway
www.sleipnergroup.com

DOCUMENT ID: 5079

REVISION: 3

DATE: 2024

LANGUAGE: EN



To download your language go to www.sleipnergroup.com

Introduction and planning for the installation

IMPORTANT NOTICE!

This manual is to be used in addition to the regular installation manual for the Sleipner thruster. This manual is intended for professionals only that can read and understand a wiring diagram and does not contain all detailed work instructions for what must be done to ensure correct and safe installation.

NOTE! To achieve maximum effect, reliability and durability from your Sleipner thruster, a correct installation as per the instructions are very important. Please follow the instructions carefully, and make sure that all checkpoints are carefully controlled.

Introduction and planning for the installation of the Sleipner series / parallel switch box.

The Sleipner series/parallel switch box have been designed to provide a safe and reliable 24V power for a 24V thruster in a 12V boat.

It has been specially designed and built to accommodate for the high current demands of an electric thruster and are available in two versions, one for the SE170TC and one for the SP240TC.

It is also designed so that there is no need for additional charging devices and connections, the extra battery will be automatically charged by the "original" charge feed in the boat for the standard battery (battery bank) that are being used as "Batt.1".

There is no need to install 2 special battery banks as one of the boats "standard" banks can be used as Batt.1, preferably the start battery bank as this is "always" full. The start battery bank is also preferred as there are normally no electronics that can be knocked out by a voltage drop or peak caused by all heavy electromotors such as a thruster.

NOTE! If you have electronically controlled engines (MMC / Volvo EDC / Morse etc.) the power to these must not be taken from the same battery as you power a thruster (or any other high power electric item). The best and most easy way to solve the power feed to such sensitive and critical items is a small extra battery for this. It is less expensive to provide a separate power feed to the electronic engine controls instead of a separate battery system for the heavy users, as the electronics have a very small power demand in comparison with a thruster, windlass and the engines starter motor.

Without exceptions, Batt.2 can have no other connections other than those described in these instructions.

We advise to install the extra battery (Batt.2) and the series / parallel switch box as close to the battery (bank) used as Batt.1 as possible.

Make sure to use heavy duty power cables for all battery and thruster connections including the ones between the batteries and the series/parallel box. The minimum cable size to use is 70mm² / 000 or more if required by the length. See list in manual for the thruster you are installing.

The series/parallel switch box is splash proof but must be installed in a dry position so that it cannot become submerged in water.

Observe and follow the minimum battery capacity ratings described here. The smallest rating is for the SE170TC and the largest for the SE210TC & SP240TC. Remember, these are minimum ratings, bigger is better.

Always install main power switches in the main positive cables from each battery bank so that in case of a failure or emergency, the power can be switched off. The boat owner / operator must be informed of the location of these switches and instructed to shut them off when leaving the boat.

We also advice to install fuses at each battery as described in the wiring diagrams.

When the thruster is not running: (see FIG.1)

The two batteries (battery banks) are connected in parallel so that the extra battery is being charged by the boats normal 12V charge system, the same charge system that is charging the standard Batt.1.

By this, the extra battery (Batt.2) becomes a full part of the Batt.1 bank and thereby also increase the capacity of this.

The box is built so that you can draw the same amount current from the extra Batt.2 as the thruster draws as the solenoids have the same capacity in their inactive position as in the active position. (And basically, nothing on a boat draws as much as a thruster). There is no power on the main positive lead to the thruster until the thruster is activated by the control panel.

The power to the thrusters control system and panel is supplied by the series/parallel switch box, via the grey and black leads to the control side of the thruster's solenoid only.

Both batteries are now at 0V - 12V.

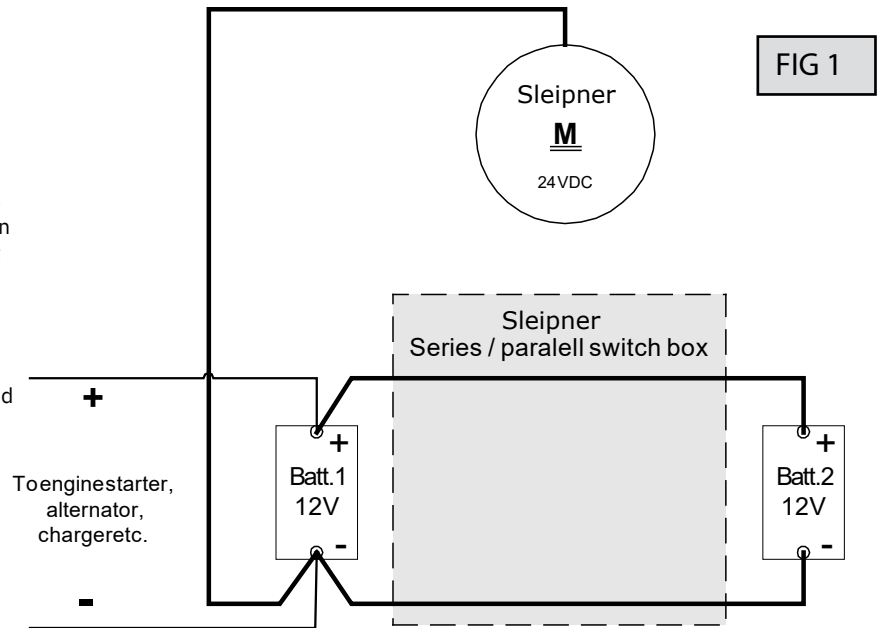

When you run the thruster: (see FIG.2)

When a run signal is sent to the thruster from the panel, the solenoids in the series/parallel box reacts first so that Batt.2 is moved into a series connection with Batt.1. so that there is 24V on the main power supply cable to the thruster.

The main contactors on the thruster does not engage until this have been done so that you have 24V at the thruster to control the 24V main solenoid contactors on the thruster.

Now, only Batt.1 is being charged while Batt.2 can only draw from its own capacity.

In this position, Batt.1 is 0 - 12V and Batt.2 becomes the 12V - 24V portion of the 24V feed to the thruster.

Batt.2 can only be connected to the series/parallel switch box as described in the manual.

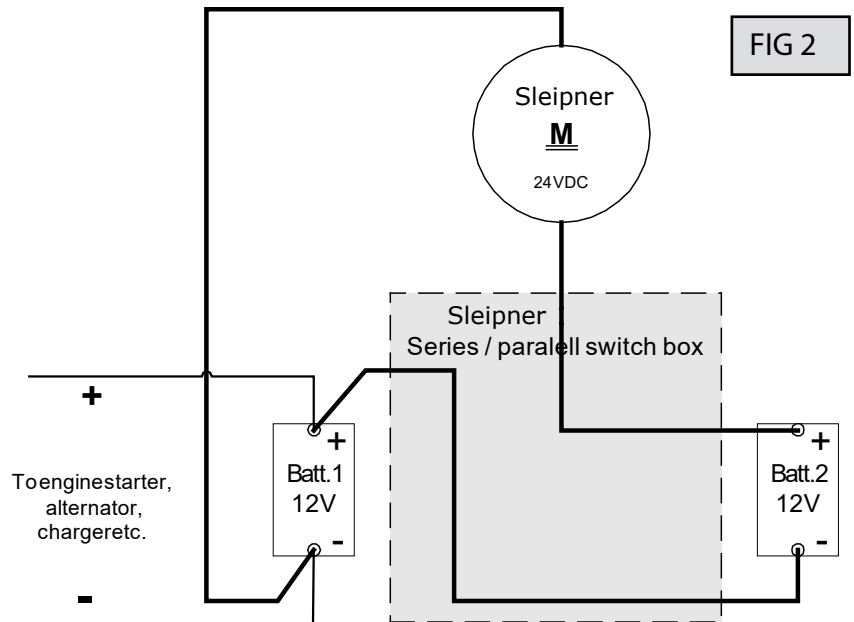

THIS IS NOT A WIRING DIAGRAM.
Only for functional illustration.

Installation

1. Install the thruster as per the installation instructions following it but disregard the wiring diagram which are being replaced by the diagrams in this manual. Make sure to use the correct main cable size according to the length to thruster as listed in the thruster's manual. **NOTE!** The length measurements in this list is the total of the + and - cable.
2. Bolt the box to a bulkhead in an accessible location as close to the two battery banks as possible. It should be positioned so that the cable openings face down.
3. Connect the heavy main cables, main battery switches and fuses as described in the "visual" wiring diagram to the thruster, series/parallel switch box and batteries. Make sure to label all cables in both ends to ensure correct connection points. Remember to fit the rubber seals around the cables and in the box. (See FIG.3 and FIG.4)
4. Check again that the main cable wiring in the system is correct!
5. Extend the included 2-lead wire coming out of the series/parallel switch box (grey and black) and connect these to the lower connectors on the thruster's main solenoid contactor. (See FIG.3 + FIG.5)
6. Install the control panel(s) as per the instructions. The panels should be connected directly to the thruster as in a "normal" installation without a series/parallel switch box.
7. If you are installing a stern thruster, make sure to follow the instructions in the stern thruster installation manual to move the electronic control box away from the thruster and seal the thruster compartment from general bilge water. The electric installation of bow and stern thrusters must be treated as separate thrusters in terms of electric wiring so that each thruster must have its own series parallel box with all the connections and a separate Batt.2 and the 2-lead control cable between the series parallel box and the thruster. There is an example diagram (FIG.6) on page 7. You can also use separate battery bank 1 for each thruster, remember the 12V charge feed as described.

NB! If you are installing both a bow and a stern thruster with series/parallel switch boxes, the Batt.1 bank can be common for both thrusters providing it has the necessary capacity (minimum x 2,5) but there must be an individual Batt.2 for each thruster. (See FIG. 6)

Minimum battery capacities

	Batt.1	Batt.2	Slow fuse / main switch rating
SE170TC	600CCA din	600CCA din	400A for 10 minutes
SE210TC	750CCA din	750CCA din	550A for 10 minutes
SP240TC	800CCA din	800CCA din	600A for 10 minutes

- CCA din is the Cold Cranking Amps rating by the DIN standard.
If your battery is rated by other standards, you should use the following factors:
DIN = SAE & BCA / 1,9 (Example: rating is 800 CCA BCA = 421 CCA DIN) DIN = IEC / 1,3

REMEMBER!

Bigger and more powerful batteries and cables will increase the thrusters performance as there will be less voltage drop to the thruster. The sizes mentioned in the manuals are the minimum sizes and the larger, the better.

Technical wiring diagram

FIG 4

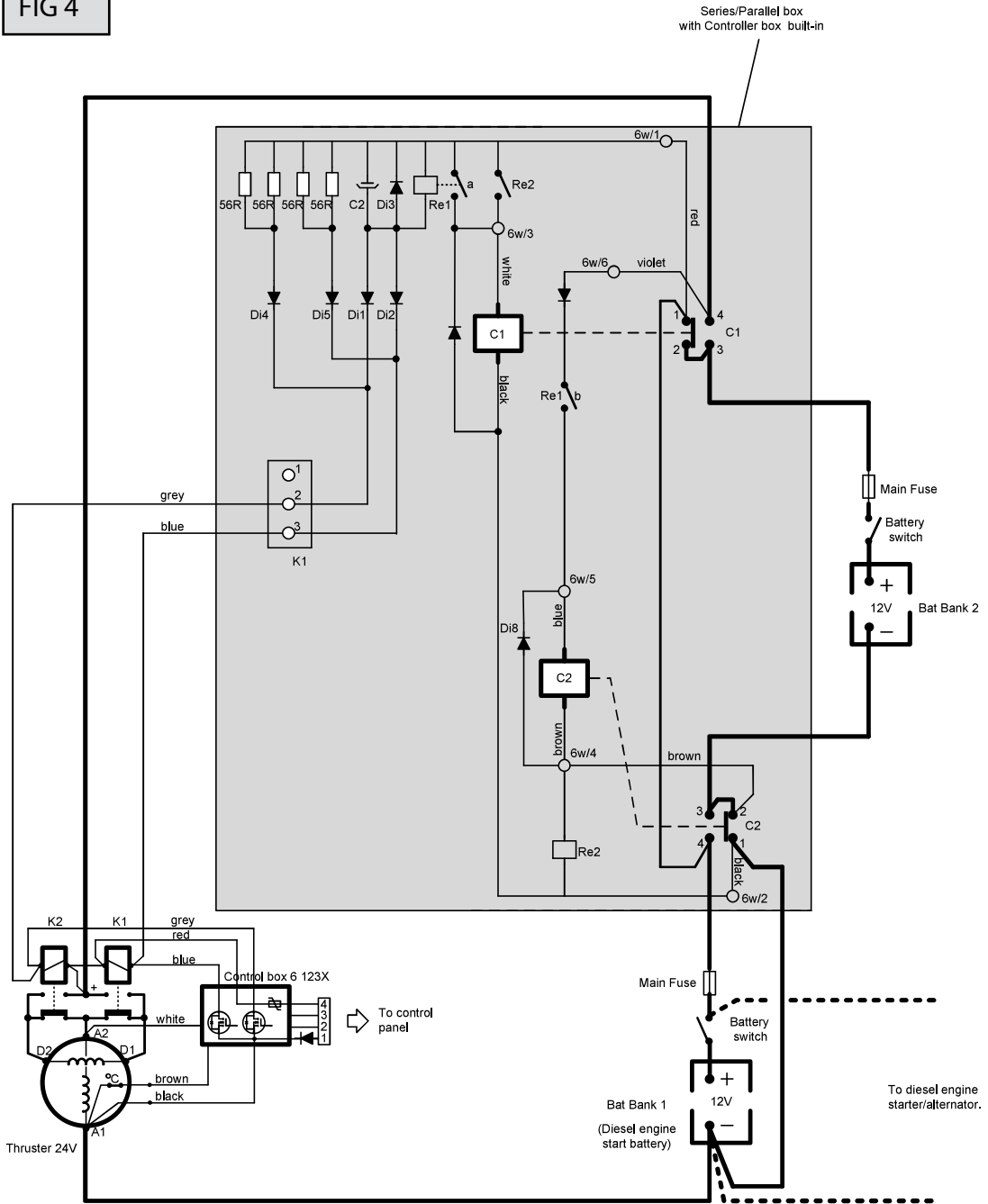

	<p>Thruster w/Serial / Parallel box 10112A and 15112A (12 to 24V) Schematic diagram</p>	<p>Sleipner Motor AS P.O. Box 519 N-1612 Fredrikstad Norway Tel: +47 69 30 00 60</p>	<p>Drawn: L.G. 2.2012</p> <hr/> <p>Draw no: EFG-000-813-01</p>
--	---	---	--

Connection on the thrusters solenoids

FIG 5

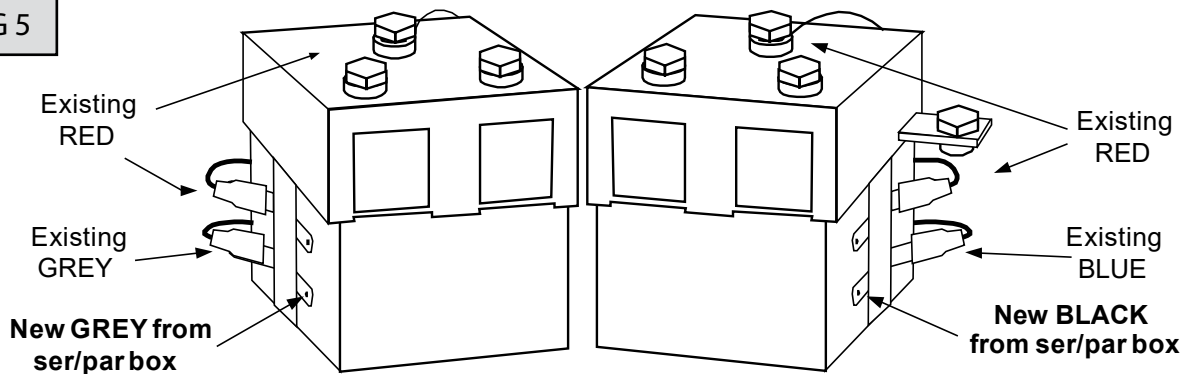

Example diagram if bow + stern thruster

FIG 6

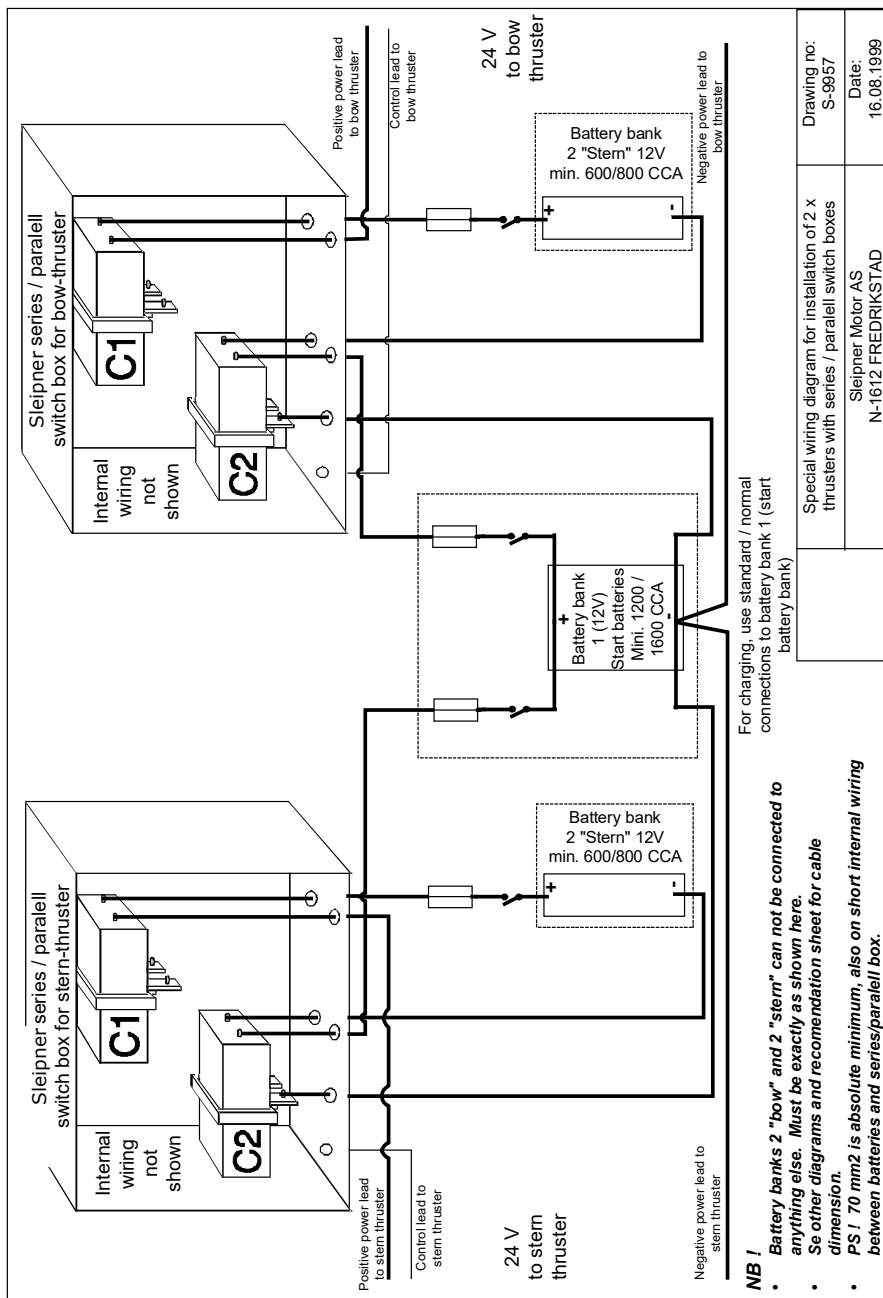

© **Sleipner Group**, All rights reserved
The information given in the document was right at the time it was published. However, Sleipner Group cannot accept liability for any inaccuracies or omissions it may contain. Continuous product improvement may change the product specifications without notice. Therefore, Sleipner Group cannot accept liability for any possible differences between product and document.

Learn more about our products at
www.sleipnergroun.com



SLEIPNER GROUP

P.O. Box 519

N-1612 Fredrikstad

Norway

www.sleipnergroun.com

Made in Norway

