

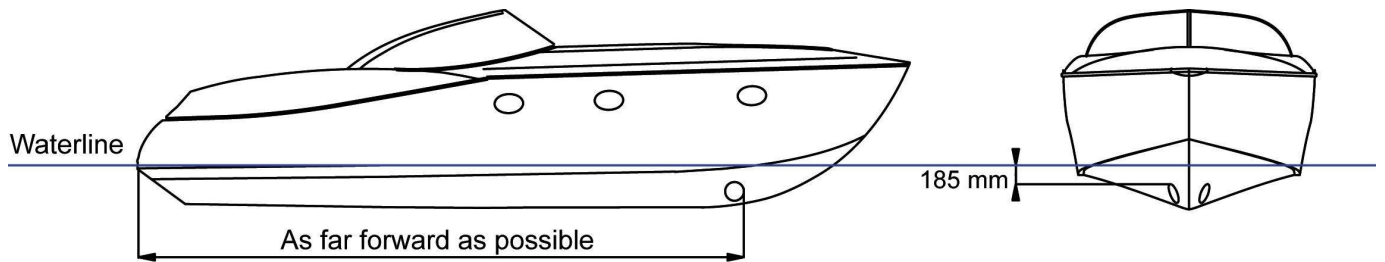



## 1. GENERAL INSTALLATION GUIDELINES

In order to install the thruster in the most efficient position, follow the instructions below:



- The **minimum** acceptable tunnel position is 139mm below the waterline
- **The tunnel is ideally positioned when the distance between the waterline and the top of the installed tunnel is 185mm**
- The tunnel must be installed as far forward as possible

NB: A thruster turbine installed above its ideal position towards its minimum depth will lead to a progressive loss of performance.

Whether inclined or horizontal, it is recommended to support the electric motor.

The batteries used by the thruster must be charged by both the main engine's alternator and an appropriate battery charger.

If the thruster is installed using a dedicated battery bank, this must be as close as possible to the thruster in order to reduce voltage loss in the electric cables.

For the **CT60-IP** mono, the **propeller** must be **centred** in the tunnel.

In the case of the **CT80-IP** duo, the drive leg must be centered in the tunnel

**In no case should the propellers of either models protrude out of the tunnel.**

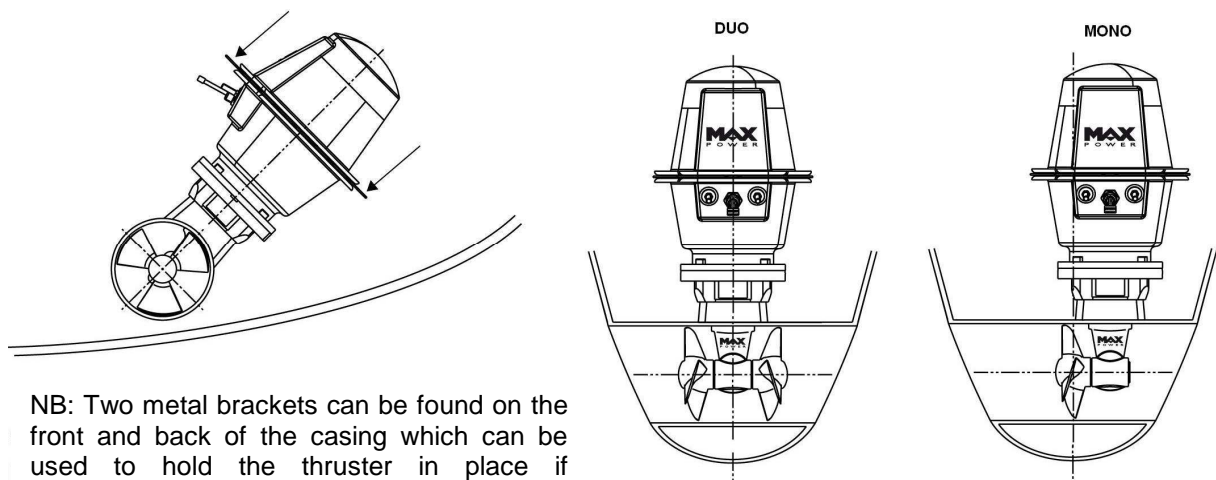

NB: Two metal brackets can be found on the front and back of the casing which can be used to hold the thruster in place if necessary.

**2. TUNNEL**

Once the final tunnel position has been determined and all dimensions have been checked, mark the centre-point of the tunnel on both sides of the hull and drill holes of 8 –10 mm Ø on either side.

Using a metal rod, construct a compass with a 100mm radius. Insert through the holes and trace the ellipses, as shown below.

After cutting the holes out following the elliptical guidelines, use an abrasive disc to prepare the inside and outside surfaces of the hull for laminating (approx. 10 to 15cm around the holes).

Position the tunnel in the hull, mark the positions of the different components, as well as the areas that require laminating, then remove the tunnel. It is advisable to drill the tunnel before laminating it into position. See section 3 "Composite Motor Support and Drive leg" for more details.

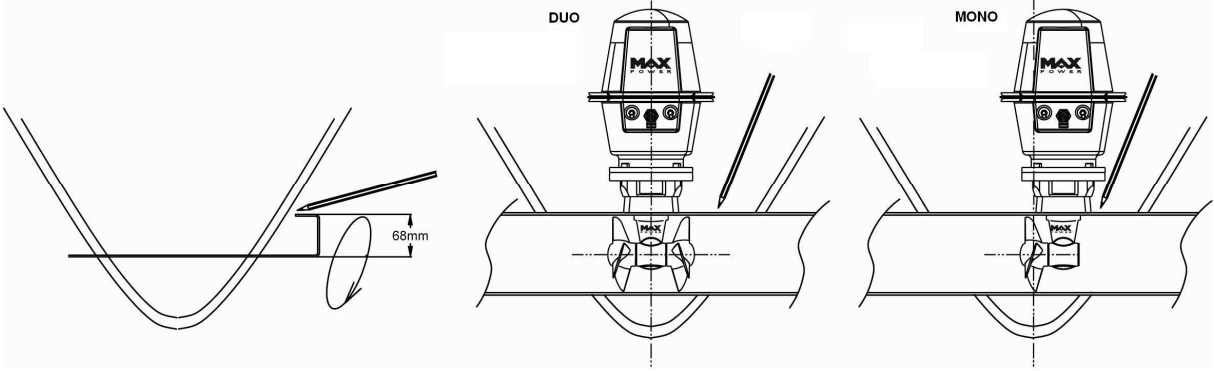

Replace the tunnel. To secure its position apply reinforced fibreglass filler to all areas, both inside and out, taking care to entirely fill the space between the hull and the tunnel. Laminate using a minimum of 8 layers of **ISOPHTALIC RESIN** alternated with mat and roving.

In difficult to access areas (i.e. under the tunnel), it is possible to only apply reinforced filler.

Once the filler has set on the outside, finish with a waterproof under coat, followed by sanding and application of a waterproof finish coat.

In order to optimise the flow of water whilst sailing, and to avoid turbulence due to the tunnel, leave 1 to 4 cm of Finish these with several coats of reinforced filler in order to obtain the required hydrodynamic lines.

Once all laminating work is complete, apply a watertight barrier.

**DO NOT LAMINATE THE AREA OF THE TUNNEL TO WHICH THE ELECTRICAL MOTOR SUPPORT WILL BE FIXED.**

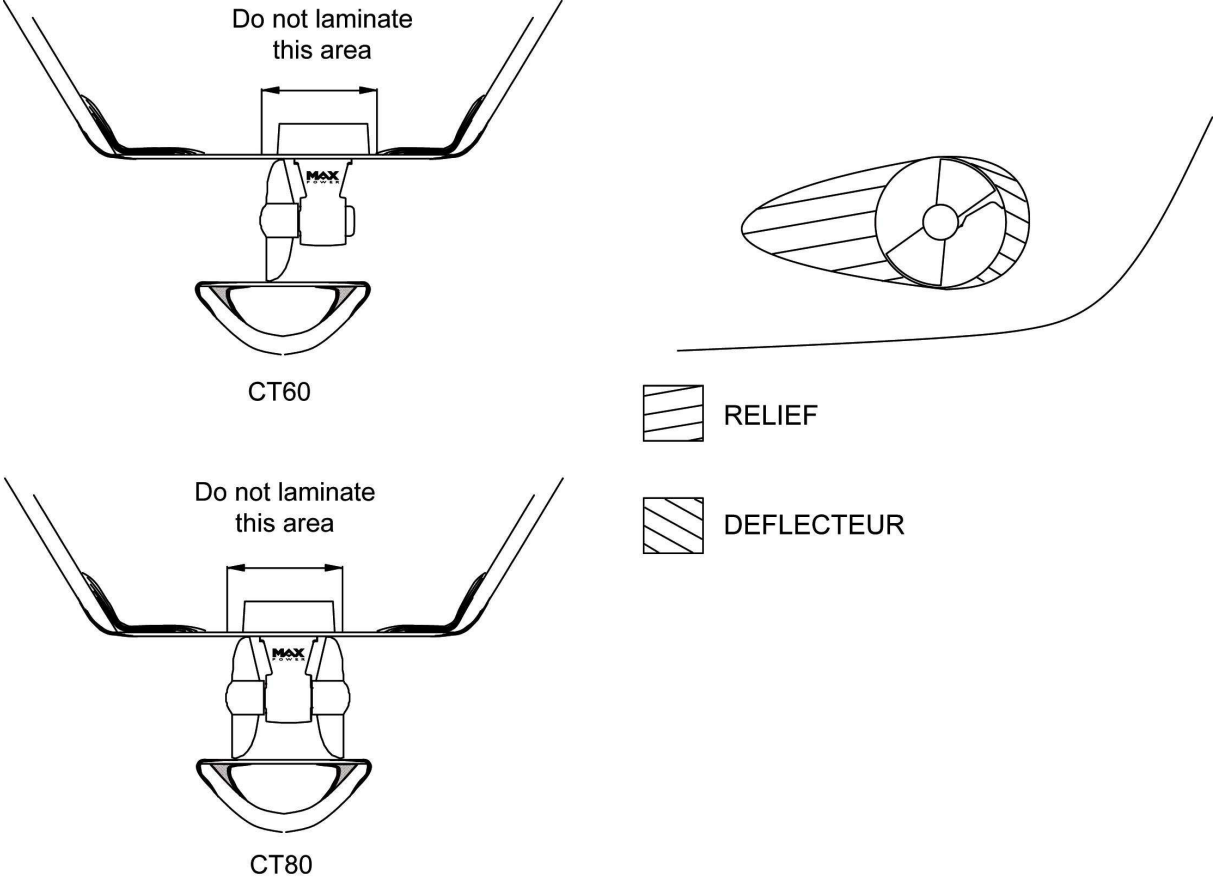

**3. COMPOSITE MOTOR SUPPORT AND DRIVE LEG**

**For the CT60-IP (Mono):**

The propeller must be at the center of the tunnel. The motor support and the drive leg will therefore not be centered in the tunnel.

**For the CT80-IP (Duo):**

The motor support and the drive leg will be centered in the tunnel.

**For both models:**

Locate and mark the intended position of the holes for the fixing screws and the leg hub. You can use the motor support and the leg's gasket to mark these holes.

In some cases it will be easier to mark and drill these holes BEFORE laminating the tunnel.

After drilling, use the gasket to verify the holes' axes and adjust them with a round file where necessary.

These holes must be completely **clean** before inserting the screws.

Position the leg, the gasket (**between the leg and the tunnel**) and the motor support, and then tighten the the two screws alternatively. Finally, mount the propeller(s) to control the general alignment.

If the general set-up is correct, remove the propeller(s), the leg and the gasket. Apply a thin coating of silicon grease or sealing compound to both sides of the gasket (this must be resistant to hydrocarbons and water). Re-assemble all parts as before,

positioning and then tightening the two 8mm Ø screws alternatively using a 5.5mm Allen key (maximum torque: 25Nm).  
Check that the propellers rotate freely, without resistance or friction.

**It is imperative that the holes and the screws remain free of sealing compound, otherwise there is a risk of an incorrect assembly of the parts.**

**Caution: do not use graphite grease.**

**NOTE:**

The composite drive leg:

- is pre-filled with oil and sealed for life
- does not require anodes
- must not be disassembled, even partially (exclusion warranty)

**4. ELECTRIC MOTOR (12 volts)**

After having greased the motor shaft and the drive pin, place the motor on its support. The motor should centre itself and align easily when correctly mounted on its support. If not, the drive leg, motor support and tunnel are incorrectly assembled. Most likely due to an uneven surface on the outside radius of the GRP tunnel. If this is the case disassemble the motor support / drive leg assembly, sand the tunnel so as to achieve a smooth exterior radius and repeat the previous steps. Position the four 8mm Ø motor support screws, then tighten them alternatively (maximum torque: 30Nm)

**5. PROPELLER(S)**

Insert the drive pin and propeller (to be carried out twice for the CT80 duo). Check that the propeller(s) turn(s) without resistance (a little resistance due to the motor is normal). Tighten the fixing screw on the side of the propeller using a 3mm Allen key (maximum torque: 3 Nm). Protect your hands during this operation to avoid risks of injuries caused by the edges of the propeller.

**IMPORTANT:** to prevent against calcium deposits that damage the seals, we recommend that you coat the shaft and stainless steel cover with silicon grease.

**6. PROTECTION GRILLS**

It is possible to install protection grills; however installation of such grills will affect thruster performance.

**7. ELECTRICAL INSTALLATION**

**CAUTION:** an incorrect electrical installation will cause rapid deterioration or even failure of the thruster. Excessive voltage drop will cause premature wearing of the relays and brushes. Special attention should be given to the quality, capacity and condition of your batteries, aswell as cable sections used.

**Ensure that all electrical connections are correctly tightened.**



**It is essential to install a manual battery isolator and if possible an electric battery isolator at the base of the thruster motor power line.**

When using a manual battery isolator it must be visible, clearly marked & easily accessible.

**Thruster motor power supply:**

These values are given as an indication, assuming that the batteries are charged at 100% and in charge, that is either 13.8V or 25.4V.

The performance data of the CT60-IP / CT80-IP is measured with an approx. consumption of 400A and 11V (12V) or 280A and 22V (24V) at the motor's connections.

Please refer to the characteristics given by the manufacturer of the batteries that will be used (see section 9 "Batteries").

**Power wiring:**

Measure the shortest and most direct route possible between the battery(ies) and the electric motor; remembering to allow for both "positive **and** negative" cables.

**Recommended cable sections:**

Cable lengths	CT60-IP / CT80-IP 12V	CT60-IP / CT80-IP 24V
L ≤ 5 m (2,5 x 2)	50mm <sup>2</sup>	35mm <sup>2</sup>
5 < L ≤ 10 m (5 x 2)	70mm <sup>2</sup>	50mm <sup>2</sup>
10 < L ≤ 15 m (7,5 x 2)	95mm <sup>2</sup>	70mm <sup>2</sup>
15 < L ≤ 20 m (10 x 2)	120mm <sup>2</sup>	95mm <sup>2</sup>

For all connections, use appropriate terminals for the cable sections chosen. It is possible to reduce the cable section to facilitate easy connection but **only over a short distance**. In this case, appropriated crimp fittings should be used at the connections.

**Please consult the "Electrical installation" diagram p. 11 for more information**

**8. MAIN POWER FUSE**

Fuse sizes for overcurrent protection are to be determined on the basis of the cable sections in the circuit and NOT the amperage drawn by the appliance (thruster motor) in the circuit.

Thruster	Maximum Amperage	Max Power Fuse size
CT60-IP / 12V	330A	160A
CT60-IP / 24V	180A	125A
CT80-IP / 12V	360A	200A
CT80-IP / 24V	200A	125A

**9. BATTERIES**

Thrusters are high amperage consumers with instantaneous demands, thus, we recommend you use maintenance-free "starting" type batteries, with high CCA outputs.

Example:

Battery: Exide Maxxima900 12V  
Capacity: 55 Ah  
CCA: 800

Thruster	Batteries number
CT60-IP & CT 80-IP 12 V	2 serials
CT60-IP & CT 80-IP 24 V	2 parallels

## 10. ELECTRONIC CONTROL BOX

**WARNING:** The electronic controller must be positioned outside of the zone at risk in which there may be potentially flammable gases.

Install a fused circuit breaker / switch in the boat's main DC distribution panel marked BOW THRUSTER.

This circuit breaker / switch should ideally be supplied from a different battery bank to the one used for powering the thruster.

The installer must protect the positive supply cable of the thruster's control box by means of a 8A fuse. The size of the power cables (red & black) depends on the length of the cable run, the voltage drop in these cables should not exceed 5% of the nominal battery voltage.

For safety reasons, and in order to obtain all the functions provided by the thruster controller, an electric battery isolator needs to be installed in the thruster motor positive supply cable.

Max Power advises the use of an electric battery isolator ref. HFI I €€ (12V)  
HFI I €€ (24V).

If an electric battery isolator is not used then simply seal-off the two grey wires coming out of the control box. It is important to isolate the thruster motor power circuit by means of a manual battery isolator after having used the thruster.

***Please refer to the drawing "Relay and control box connections" p. 12 for more detail on the wiring of the control box to the thruster.***

## 11. CONTROL PANEL AND THRUSTER CONTROL BOX FUNCTIONS

To switch the thruster ON or OFF follow the instructions given in the diagrams on the following page.

When switched ON the control panel will beep once and the green LED in the red push-button will light up.

When switched OFF the control panel will beep twice and the green LED in the red push-button will go out.

The thruster controller provides a time delay between left and right thrust in order to avoid rapid direction changes. There is no delay when thrusting to same side.

If the thruster motor overheats the control panel will start beeping and the green LED will flash until the thruster motor has cooled down.

As soon as the overheating alarm sounds, there are 10 seconds of actual thruster use before the unit automatically shuts down. It will then not be possible to switch the thruster on until the motor has cooled down.

**If the thruster has not been used for a period of thirty minutes it will automatically switch itself off.**

Before switching off automatically the control panel will beep once followed by a second beep a few seconds later, after which the thruster switches itself off.

In order to isolate the thruster motor power circuit, as described in the previous two paragraphs, it is necessary to install an electric battery isolator, as advised by Max Power.

***Please consult the "Electrical installation" diagram p. 11 for more information***



## Control Panel Instructions

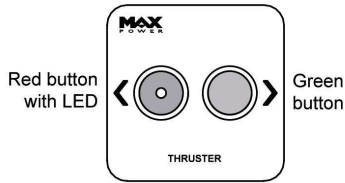

### Touch panel :

To switch the thruster on or off, **push and hold down both the red and green buttons** for several seconds.

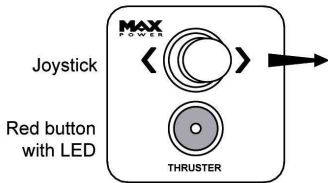

### Simple Joystick :

To switch the thruster on or off, push and hold down the red button whilst pushing the joystick to the right for several seconds.

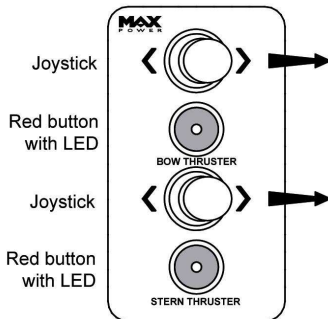

### Double Joystick :

To switch the thruster on or off, push and hold down the red button whilst pushing the joystick to the right for several seconds. This is the same for both the Bow thruster and the Stern thruster.

## 12. CONTROL PANEL INSTALLATION

Control panels should be protected from the natural elements while the thruster is not in use.

Install the control panel(s) in easily accessible positions, without obstructing the main engine and/or steering controls.

When fixing the panel with the stainless steel screws, make sure to install the pre-cut rubber seal, as supplied with the panel, ensuring that it is in the correct place.

 Only when totally finished and satisfied with the wiring and positioning of the unit, clip-on the face panel/cover.

Please note that panels are only fully waterproof from the front, if installed correctly. However the area behind the dashboard should be kept dry to avoid the risk of oxidization of the cable connector contacts.

**For full control panel installation instructions, please refer to the "Installation Guidelines" as supplied with each control panel.**

## 13. TESTS

 **Activating the thruster when the boat is out of the water, is not advised under any circumstances.**

**Tests must be carried out with the boat in the water, the battery(ies) charged at 100% and in charge, and the engines running.**

The maximum continuous operating runtime corresponds to S2-3mn norm. However, this can be affected by the ambient temperature.

## 14. ELECTRICAL MEASUREMENTS

In normal “usage” mode, i.e. thrusters running, boat in the water, with fully charged batteries under ongoing charge (alternator), electrical measurements should be made at the following points:

At the batteries

At the battery cut-off switch

At the fuse

At the electric motor’s connections

At the power supply arriving at the thruster control box

These measurements will enable you to detect voltage drop.

**NOTE:** the voltage reading between the motor’s negative and positive connections should be approximately **10.5V for 12V models or 22V for 24V models during operation.**



The cumulative effect of voltage drops at these points can severely impair the thruster's performance.

Should the voltage measured be too low, the following points need checking:

Are the batteries of sufficient capacity ?

Are the batteries good quality?

Are the batteries sufficiently charged?

Are appropriate cable sections being used?

Are the connections sufficiently tightened?

## 15. OPERATION

With the control system circuit breaker/ switch and manual battery isolator switched on:

Switch on the control panel, as previously described in the manual.

Push the red button or incline the joystick to the left and the boat moves to the left.

Push the green button or incline joystick to the right and the boat moves to the right.

If, during tests the boat moves in the wrong direction, change around the blue and the brown wires on your power relay.

When manoeuvring remember that the boat’s momentum continues after you release the joystick / button, therefore remember to release the control prior to reaching your desired position.

Care must be taken not to use the thruster in areas where there may be people swimming or floating debris.

Maximum running time: 2-3 min (depending on ambient temperature).

## 16. ALARMS OR THERMAL SWITCH-OFF

The thruster's electric motor is fitted with a thermal switch as standard. If the thruster motor overheats the buzzer in the control panel will start beeping and the green LED in the red-push button will flash until the thruster motor has cooled down again.

As soon as the overheating alarm sounds, there are 10 seconds of actual thruster use before the unit automatically shuts down. The unit will then not be able to be switched on again until the motor has cooled down.

**17. SAFETY**

Switch off means to cut the power at both the DC equipment panel (control power supply) & the thruster battery isolator (thruster power supply) after having used the thruster. Under no circumstances should any flammable products be stored next to the electric components of the thruster. Care must be taken not to use the thruster in areas where there may be people swimming or in the water close to the thruster.

**CAUTION:** Never tamper with the thruster / thruster turbine if not 100% sure that both the control and power circuits have been isolated, except if taking electrical measurements on the thruster motor or relay.

**18. MAINTENANCE**

**WARNING: Under no circumstances should the thruster casing be opened.**  
Opening or modifying the thruster may result in it no longer being Ignition Protected. In case of a problem please contact your local Max Power distributor

Control panels should be protected from the natural elements while the thruster is not in use.

The thruster requires a minimum of ongoing maintenance:  
Check the condition and charge of the batteries regularly, as voltage drop is the most frequent cause of rapid deterioration of the relay.  
Carry out a regular check of all electric components: batteries, connections, power cables.

**NOTE:** All maintenance should be carried out by qualified and authorised personnel.

**Composite drive leg and propellers:**  
The composite drive leg is pre-filled with oil and sealed for life. It does not require the oil changing.  
The composite drive leg does not require an anode.  
The composite drive leg must not be disassembled, even partially (this would void the warranty).  
When the boat is out of the water, check that there are no fishing lines, plastic bags, etc. caught in the propellers.  
Paint the drive leg and propellers with antifouling (make sure that they were well prepared and primer has been used).  
Always keep the propellers and tunnel clean.  
To prevent the build up of calcium on the drive shafts, which would damage the oil seals, cover the drive shaft and the oil seals' stainless steel covers with silicon grease before fitting the propeller(s). This should be done on an annual basis after the cleaning of the outside of the leg. Do not use aggressive solvents as they may damage drive leg seals.  
If drive leg oil seals are found to be worn, replace the drive leg with a standard exchange unit.

**THE MAX-POWER TEAM WISHES YOU SUCCESSFUL MANOEUVRING AND ENJOYABLE CRUISING**

## 19. ELECTRICAL INSTALLATION DIAGRAM

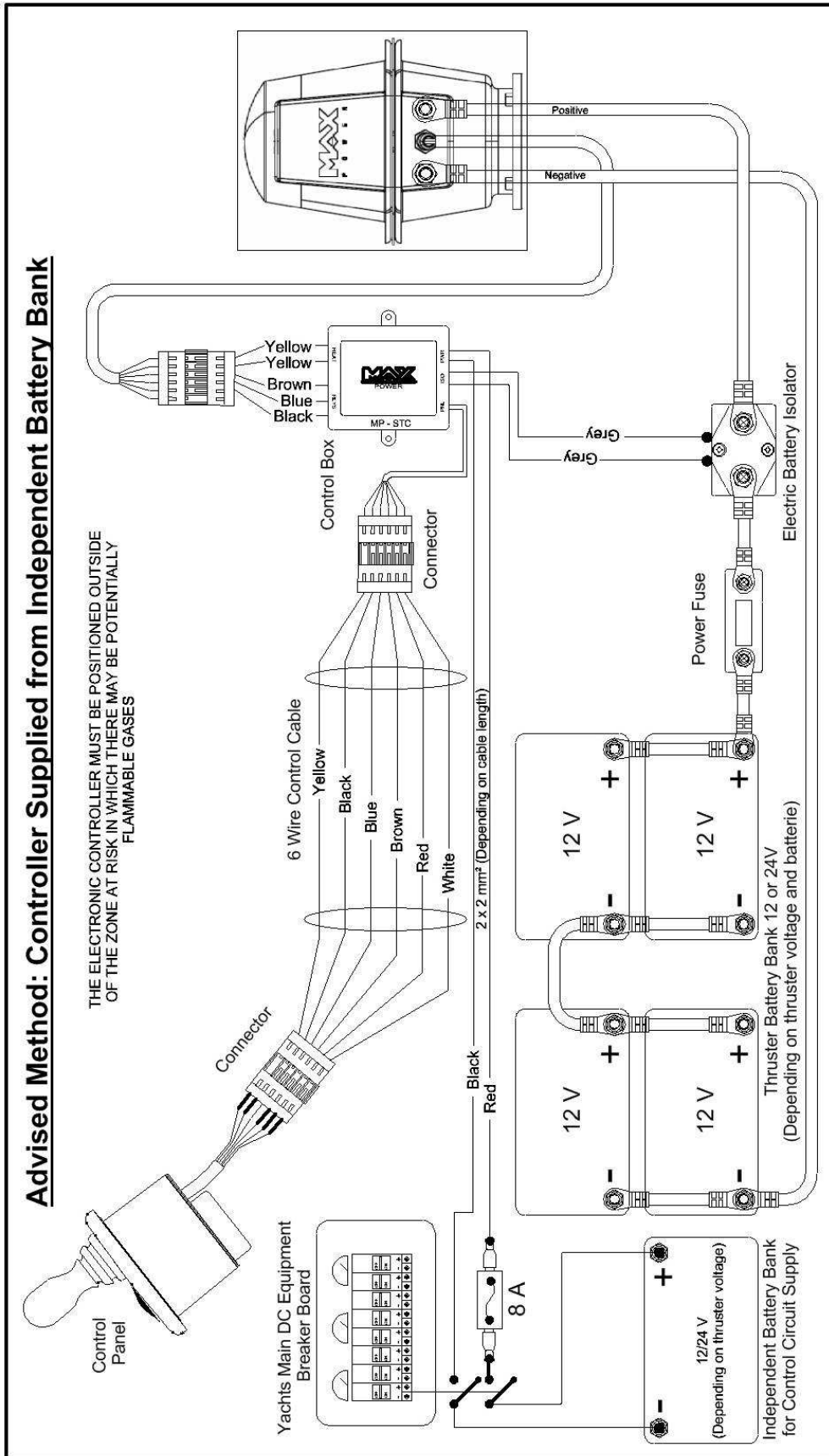

## 20. RELAY AND CONTROL BOX CONNECTIONS

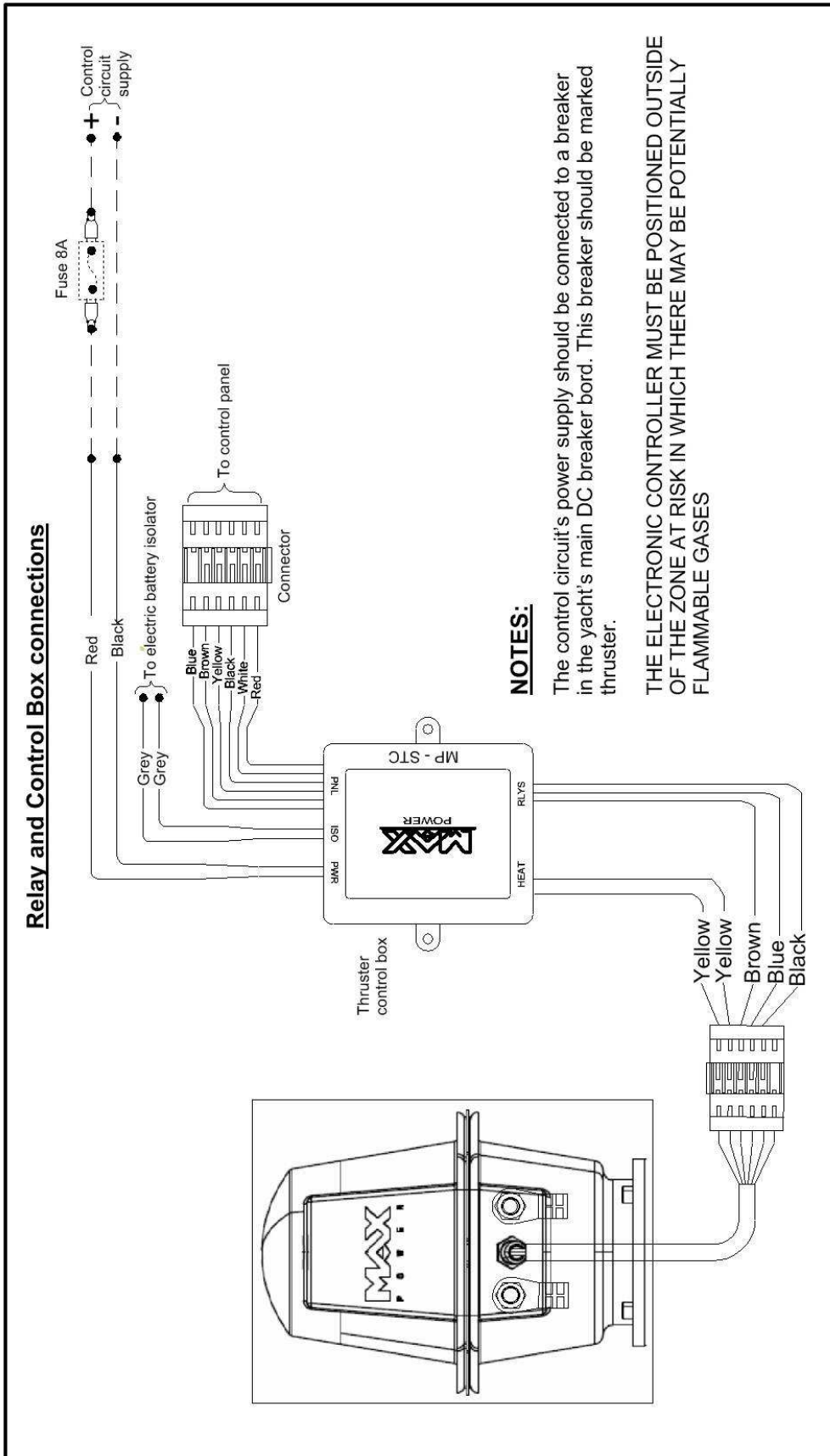

### 21. SPARE PARTS DIAGRAM

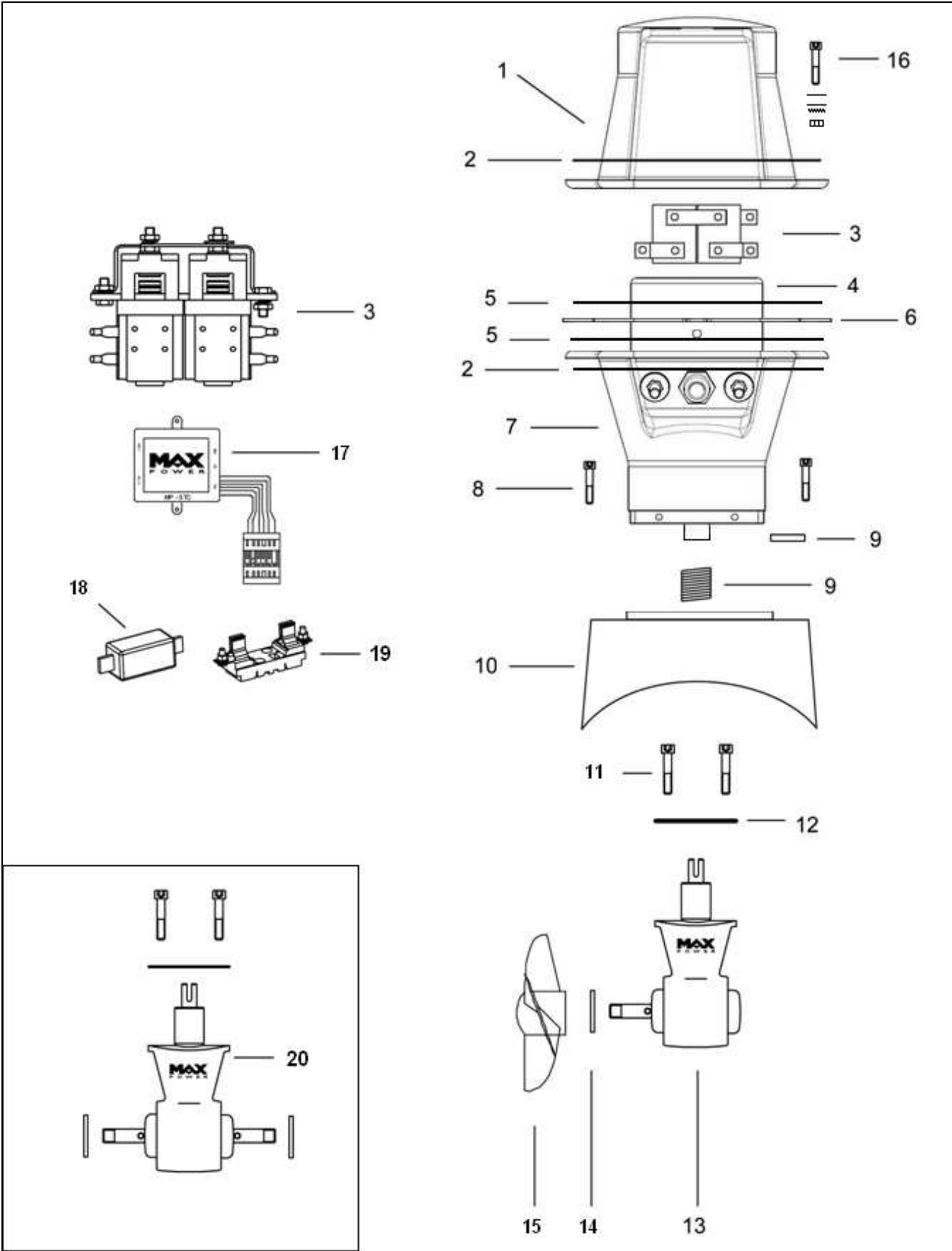

## 22. SPARE PARTS LIST CT60-IP / CT80-IP

N°	Description	Quantités	Référence
1	Upper motor casing	1	MPOP5836/SUP
2	Backing flange	2	MPOPO5217
3	Complete relay 12V	1	MP083056/2
3	Complete relay 24V	1	MP083057/2
4	Electric Motor CT60-IP / CT80-IP 12V	1	MP053030
4	Electric Motor CT60-IP / CT80-IP 24V	1	MP053031
5	Flange gasket	2	MPOP5832
6	Centre flange	1	MPOP5216
7	Lower motor casing	1	MPOP5836/INF
8	Motor fixing screws	4	MPOP5241
9	Motor drive pin and spring	1	MP058033 MP058032
10	Motor support	1	MP058035
11	Drive leg fixing screws	2	MPOP4130
12	Drive leg / tunnel fibre seal	1	MPOP2060
13	Composite drive leg CT60	1	MP058100
14	Propeller drive pin	1 ou 2	MPOP5221
15	Propeller	1 ou 2	MPOP8080
16	Motor casing screw kit	16	MPOP4051
		16	MPOP4049
		16	MPOP4048
		32	VP084200
17	Electronic control box	1	MPOP5701
18	Fuse CT60-IP 12V (160A)	1	OPTI3115
18	Fuse CT80-IP 12V (200A)	1	OPTI3112
18	Fuse CT60-IP & CT80-IP 24V (125A)	1	OPTI3114
19	Fuse holder T1	1	OPTI3119
20	Composite drive leg CT80	1	MP088100
-	Fuse extraction handle	1	OPTI3118

**23. TROUBLESHOOTING GUIDE**

Before contacting your nearest Max Power distributor, please check the below troubleshooting guide.

Problem	Check
The control panel does not light up	<ul style="list-style-type: none"> <li>• Check the 6 wire connector behind the joystick</li> <li>• Check the thruster's electronic control box 6 wire connector</li> <li>• Check the circuit breaker / switch in the boat's main DC distribution panel</li> <li>• Check the control box's power fuse (8 A)</li> </ul>
The relay is clicking but the motor is not running	<ul style="list-style-type: none"> <li>• Check the motor's power fuse</li> <li>• Check the main battery isolator</li> <li>• Check battery conditions and connections</li> <li>• Check the internal relay contacts</li> </ul> <p style="text-align: center;"><b><u>WARNING</u></b>  <b>Only a qualified technician should check these points to ensure that the thruster is correctly reassembled and remains Ignition Protected.</b></p>
The motor is running but the thruster is not working	<ul style="list-style-type: none"> <li>• Check the propellers are fitted</li> <li>• Check the motor / drive leg assembly</li> <li>• Check that the tunnel is not obstructed or the propellers blocked</li> </ul>
The thruster lacks power	<ul style="list-style-type: none"> <li>• Check the propellers are fitted</li> <li>• Check the size of the batteries</li> <li>• Check the batteries are sufficiently charged</li> <li>• Check the connections are tightened correctly</li> <li>• Check the power cables sections  <i>(See p. 6 : Recommended cable sections)</i></li> </ul>

**24. WORLDWIDE DISTRIBUTION NETWORK**

To locate the nearest Max Power distributor, please consult the section "Worldwide Distribution" on our website: [www.max-power.com](http://www.max-power.com)



## Introduction

The purpose of this document is to set out the terms of warranty cover offered in relation to products purchased by the End User from Max Power or its approved network of resellers.

## 1. Definitions

- **Authorized Repair Number:** The number given by Max Power on reporting a fault with your thruster
- **Dealer:** An authorized Max Power sales centre
- **End User:** The boat supplied with supplied equipment and the owner thereof
- **Installer:** The authorized centre responsible for the installation of your thruster
- **Manufacturer:** supplier of the equipment under warranty
- **Pleasure Craft:** Vessels used for owner's personal use that have no commercial use (i.e Charter boats or work boats)
- **Resellers:** Max Power approved distributors and dealers
- **Serial Number:** Number in upper right hand corner of Warranty document
- **Supplier:** The manufacturer (Max Power)
- **Warranty:** The terms and conditions that are covered by the manufacturer

## 2. Period of Coverage

The equipment manufactured by the Supplier is guaranteed to be free from defective workmanship, components and materials under normal usage conditions for a period of three (3) years from the date of purchase by the End User. This warranty is transferable to subsequent owners of this equipment during the period of coverage.

## 3. Warranty Registration

Register your purchase now at [www.max-power.com](http://www.max-power.com). (NB. proof of purchase must be kept throughout the warranty period)

## 4. Warranty Terms

If the material is used for anything other than for pleasure craft, the guarantee is limited to a six-month period.

**Year 1:** All factory testing, diagnosis, repairs and replacements are performed at no charge to the End User; All parts and up to two hours of labour are covered for repairs and replacements conducted in the field.

**Year 2 & 3:** All factory testing, diagnosis, repairs and replacements are performed at no charge to the End User.

This excludes any damage or faults occurring from normal wear and tear on the following items: engine, oil seals, relay contacts (If warranty is registered within the 3 month period following installation)

## 5. Warranty Exclusions

- Damage due to modifications or installation contrary to published specifications
- Cost of hauling the boat
- Damage due to repairs performed by an unauthorized service centre
- Damage due to lack of normal maintenance services
- Damage due to water
- Parts replaced due to normal wear and tear
- Repairs performed without knowledge of manufacturer (please contact dealer to receive Repair Authorization Number)
- Tampering of equipment by the End User
- Cost of travel to and from the job site
- Cost of economic loss, including injury to any person, damage to property, loss of income or profit, communication, lodging, inconvenience
- Consequential damage due to failure, including those arising from collision with other vessels or objects

## 6. Procedural Guidelines

PLEASE VIEW THE TROUBLE SHOOTING LIST ON THE MANUAL OF YOUR PRODUCT TO ASCERTAIN OR SOLVE ORIGIN OF PROBLEM PRIOR TO CONTACTING THE DEALER/INSTALLER

1. Contact your dealer/installer to report the problem.
  - If you do not know who this is, contact the nearest Max Power distributor
  - If you are in foreign waters, please contact the nearest Max Power distributor
2. Ensure you have your serial number and model number to hand (top right hand corner of warranty)
3. Dealer/Installer will come to site to decipher the cause of the fault
4. If the cause of fault is due to a manufacturing problem the dealer will contact Max Power to receive Repair Authorization Number.
5. If the problem is due to an installation error please contact your installer.

IF POSSIBLE: PLEASE TAKE PHOTOGRAPHS OF THE THRUSTER TO SHOW PROBLEM

## 7. Service Centers

Please go online [www.max-power.com](http://www.max-power.com) to find the authorized service station of your area.

The warranty as outlined above is only applicable to Max Power manufactured thrusters and optional equipment as used in marine pleasure industry. The supplier holds the exclusive right to test the product and determine whether it is defective