

MAX POWER

MAX POWER

THRUST IT TO THE MAX

MANUAL

FOR

MAX POWER RETRACT R600 SERIES THRUSTERS

FOR _____

BUILT BY _____

DELIVERED _____

∫ *A copy of this manual must remain
on board for consultation.*

MAX POWER

CONTENTS

INTRODUCTION

- P3 CONTACTING MAX POWER
- P3 IMPORTANT GENERAL INFORMATION
- P3 CHECK LIST FOR THE PROJECT MANAGER

DETERMINING BEST EQUIPMENT LOCATION

- P4 OF THE RETRACT THRUSTER UNIT
- P5 OF THE AUXILIARY EQUIPMENT

INSTALLATION PROCEDURES

- P5 CONSTRUCTION OF THE MOUNTING BASE
- P5 THRUST PLATES
- P6 CONSTRUCTION OF HULL OPENING & CLOSING PLATE
- P7 FINAL FITTING OF THE RETRACT UNIT TO THE MOUNTING BASE
- P7 FINAL ADJUSTING OF THE CLOSING PLATE
- P8 RAISE/LOWER POWER PACK INSTALLATION
- P8 TRANSMISSION LUBE OIL TANK INSTALLATION
- P9 HYDRAULIC POWER SYSTEM INSTALLATION
- P9 ELECTRICAL SYSTEM INSTALLATION

CONTROL SYSTEM

- P10 CONTROL SYSTEM MAX POWER SUPPLY
- P10 CONTROL SYSTEM PLC (NON MAX POWER SUPPLY)

CHECKS, TESTS & ADJUSTMENTS

- P11 BEFORE LAUNCHING
- P11 AFTER LAUNCHING

OPERATION AND USE

- P12 OPERATING PROCEDURE
- P12 GENERAL OPERATING INFORMATION
- P 13 TROUBLESHOOTING GUIDE

MAINTENANCE OF THE RETRACT

P 14

PROJECT MANAGERS CHECK LIST

P 16

TEST RESULTS FORM

P 17

MAX POWER

INTRODUCTION

AFTER SALES SERVICE

ADDRESS :

MAX POWER
Via Philips 5, 20900, Monza (MI), Italy
TEL : + 39 039 200 1973-936
FAX: + 39 039 2004299

RETRACT SERIAL N° S 01. R600.

IMPORTANT GENERAL INFORMATION

With a constant concern of improving our products, we reserve the right to make changes to this manual without prior notification.

All statistics and explanations within this manual were believed to be correct at the time of printing.

Each RETRACT installation requires a preliminary study of performance and feasibility.

This study covers 3 distinct sub systems:

1. The RETRACT thruster unit, (positioning, space available, structural compatibility etc)
2. Hydraulic equipment, (positioning equipment, power available, flows pressures pipe sizes etc)
3. Electrical equipment, (positioning, power supply, PLC sequencing, protection / isolation, etc)

CHECK LIST FOR THE PROJECT MANAGER

It is very important to carefully read the entire manual before starting the installation.

MAX POWER

At the end of the manual, you will find a MAJOR POINT CHECKLIST when you are inspecting the work of your installers. All the points listed must be strictly respected for the proper and safe operation of the RETRACT system.

The RETRACT should be installed by a professional specialising in this type of installation.

Architects, construction shipyards and surveyors should be contacted before installation.

All official bodies or classification experts should be contacted before the installation. All mechanical installation must apply with the conditions as laid down in the country of the boats registration.

All electrical installation must apply with the conditions as laid down in the country of the boats registration origin.

All hydraulic installation must apply with the conditions as laid down in the country of the boats registration origin.

WARRANTY REQUIREMENT

IMPORTANT: All Test readings must be filled out on the form provided and sent to Max Power by fax no later than one week after the water tests have been completed so that the Max Power standard warranty is correctly validated. This form is attached at the end of this manual.

DETERMINING BEST EQUIPMENT LOCATION

POSITIONING OF THE RETRACT UNIT

IMPORTANT: Correct positioning is essential for correct operation.

(See drawing 1)

The turbines centre requires being 900 mm below the water line when fully extended.

In other words the turbine should be at least one full diameter below the water line.

The following considerations must be taken into account when determining the position of the RETRACT.

- The space available given the vessel's fixtures, space and shape, and the installation at the farthest point forward (or aft) while respecting the minimum immersion of the turbine.
- The structural compatibility of the mounting base.
- The access needed for installation, and **complete removal of unit.**
- Sufficient access for all maintenance procedures must be allowed for.
- That the turbine when down is clear of all obstacles that might disturb water flow.

MAX POWER

IMPORTANT: Always check and make sure that there is enough room to allow for complete removal of the RETRACT unit, and room for the connection of the hydraulic piping.

LOCATION OF THE AUXILIARY EQUIPMENT

The transmission lube oil tank and the hydraulic directional valve should be located near the RETRACT unit, but in an accessible and dry place.

The hydraulic oil reservoir must be located above the water line, above and as near to the pump as possible there must be no sharp elbows between the pump and the oil tank.

The control panel (s) joystick (s), or foot switches are to be installed as required at helm stations. The remote control box is to be installed in a convenient dry and well-ventilated position.

INSTALLATION PROCEDURES

CONSTRUCTION OF THE MOUNTING BASE

The general method and materials used must be adapted to the particular hull material (laminated wood, GRP, sandwich, aluminium, or steel). Naval Architects, Classification Societies or engineering firms should be consulted.

The thruster's mechanical stresses are spread over the hull by the mounting base and the guide blocks. Installation, which should be executed by welding or bonding to the hulls plating, normally reinforces the hull, the mounting base should be attached to frames and stringers as well. The guide blocks should be replaceable should they be found worn at a later date.

After the mounting base has been made, the RETRACT should be temporarily secured on the flange to check its height its, centring, the accessibility of fittings

THRUST PLATES

Another important reason for this is to determine the exact location of the two thrust plates.

These plates are to be fabricated by the installer from a suitable material.

The thrust plates distribute the thrust forces to the hull. They should be fixed to the interior of the mounting base so that they will be directly in contact with the thrust pads when the turbine is fully extended (See building plan).

GRP HULLS: The mounting base may be moulded into the hull during construction or prefabricated, and then laminated onto the hull later.

METAL HULLS: The mounting base may be constructed with the hull or prefabricated, and then welded onto the hull later.

MAX POWER

IMPORTANT: In both cases, the top surface of the mounting base (the flange) must be given **particular attention** and machined perfectly flat in order to accept the « O » ring seal of the RETRACT base flange and ensure perfect water tightness.

The bolts fixing the RETRACT onto the mounting flange must be inserted from top to bottom.

Provide sufficient access underneath the flange to allow for tightening the nuts. If the access is not possible, provide a special mounting flange with metric 16 mm studs or tapped holes.

CONSTRUCTION OF HULL OPENING & CLOSING PLATE

The opening is closed by a plate, which may be made from the cutout hull section, or specially fabricated.

This closing plate should bear against a gasket fixed to a **20 mm wide rebate** when in the raised position.

While the hull opening closing plate is being fabricated, the RETRACT must be temporarily secured on the mounting base flange to facilitate correct closing plate installation.

The closing plate **must be fixed** to the fabricated aluminium adjustable mounting, which should have 4 elongated holes for re adjustment at a later date.

To obtain a perfect hull plate fit follow these instructions

With the thrusters securely bolted down on its flange, install the hull plate bracket on to the mounting points. Score the bracket and the mounting points to mark the position in which it is fitted (1).

Raise the thrusters to its highest position and then remove the locking knuckles. Fit the locking point adjusting tools in their place. Then lower the thrusters onto its locks (2).

Take the finished and formed hull plate and place four piles of bedding compound on the back of the plate. Then push the plate firmly into its recess in the hull, and hold in place until total curing of the compound (3).

Remove the locking point adjusting tools and refit the locking knuckles.

Unlock and lower the thrusters then reinforce bond between the bracket and the hull plate with mechanical fasteners as per construction technology (4).

A gasket needs to be installed in the hulls rebate. This gasket can be made either out of sealed cell neoprene rubber or moulded in «SIKAFLEX » (or a similar product) to form a flexible seal. Precaution must be taken to ensure that the flexible gasket does not glue the closing plate to the hull while drying. The plate must rest evenly, on the gasket with a reasonable pressure.

The closing plate should be tested for adjustment at this point, raise and lower the unit a few times.

IMPORTANT: To prevent marine growth inside the casing, it is essential that once the unit is raised, no light be allowed to enter the turbine enclosure. Therefore the closing plate gasket is essential and requires careful and permanent fixation.

MAX POWER

NOTE: Never use antifouling or other paints on the RETRACT unit.

FINAL FITTING OF THE RETRACT UNIT TO THE MOUNTING BASE

CAUTION: To ensure absolute cleanliness, hydraulic lines and ports must remain plugged until final connection.

Final installation on the mounting base must be made after thoroughly cleaning and then liberally coating both joint surfaces (case and base) with good quality marine grease. This is so that the « O » ring seal is compressed flat, evenly, smoothly and squarely when the bolts are tightened.

CAUTION: Under no circumstances should the RETRACT be glued or bedded down with a marine type mastic/glue such as Sikaflex or other similar product.

The flange bolt should be tightened sequentially and in successive passes until the two surfaces touch. If desired, a torque wrench can be used and the bolts can be tightened to a torque of 5,0 kg/M. The flange bolts should be metric size 16 mm of stainless steel, and should have a large stainless steel washer placed above a nylon washer. The nylon washers avoid stainless steel contact with the aluminium case. The nuts should be NYLOCK self-locking type.

The 4 lifting lugs provided by MAX POWER should be put in a small plastic bag, along with the hydraulic pipe plugs, for storage and future use by the ships crew.

FINAL ADJUSTING OF THE CLOSING PLATE

Once the thruster is permanently bolted onto the mounting base, reinstall the plate and check it's adjustment.

Adjust the closing plate so that it fits evenly and squarely in its hull recess.

When testing the cover plate fit,

Two rubber blocks have been placed on the top of the turbine to help adjust the closing plate in the correct position. **Tighten its fixation bolts then remove the rubber blocks.**

RAISE / LOWER POWER PACK INSTALLATION

The raise/lower unit should be near the RETRACT unit. It should be installed in a readily accessible and dry place.

It should be connected to the control box with 2 x 6 mm² cable for the motor power and 3 x 2 mm² for the up down spool valves. The up / down unit motor is protected by a 25 ah fuse found in the control box.

The hydraulic ports (LA and LB) on the raise/lower pump unit and the raise/lower ram (VA and VB) must be connected A to A and B to B.

The flexible hoses must be 1/4 " with an operating pressure rating of at least 100 bars.

MAX POWER

CAUTION: to prevent the risk of electrical earth leakage's, the hydraulic hoses connected directly to the RETRACT should be non-conductive (non-metal braided hose) high-pressure thermoplastic hose. **Absolute internal cleanliness is essential.** After pipes and hoses have been equipped with their fittings, they must be blown out with compressed air, and then plugged until connected.

The pressure limiter on the unit is pre set and should need no adjustment!

HYDRAULIC POWER SYSTEM INSTALLATION

Hydraulic power system general

A RETRACT R600 Can take up to 200 LPM of hydraulic flow this will causes on a normal installation 250 bar pressure at the thrusters inlet ports.

NOTE variations of approximately 10% are possible depending on hull shape and immersion depth.

The hydraulic power system should be designed in consequence.

The hydraulic power system must start the thruster gently (soft start) either by using a ramping valve or by using a 2 stage slow / fast speed bypass system.

The control box is equipped for both but may need re programming.

All the hydraulic power equipment, such as the piping, reservoir, pump, directional valve, etc. should be installed in compliance with the usual rules of accessibility to enable periodic checks and maintenance.

MAX POWER recommends the use of **ISO GRADE 15 to 32 hydraulic oils** for the power circuit.

PRESSURE PIPING

All hydraulic high pressure power circuit piping must comply with high pressure standards, and have a diameter at least equal to that recommended in order to reduce pressure loss especially when the installation's layout requires long hose lines.

All power circuit piping must have a continuous service pressure rating of at least 300 bars. Fittings must be of good quality, and crimped as per manufacturers instructions.

The pump intake hose line (from the reservoir) must be of a quality that is not subject to pinching or crimping.

This hose should preferably be shorter than 2 meters and have no 90-degree elbows bends.

CAUTION: to prevent the risk of electrical earth leakage's, the hydraulic hoses connected directly to the RETRACT should be non-conductive (non-metal braided hose) high-pressure thermoplastic hose. **Absolute internal cleanliness is essential.** After pipes and hoses have been equipped with their fittings, they must be blown out with compressed air, and then plugged until connected.

MAX POWER

RESERVOIR

The reservoir should be mounted as close to the pump as possible and must always be higher than any other component in the system. The reservoir must be mounted at a height that allows the breather to be situated 500 mm, or higher, above the waterline. If this is not possible, then the breather can be removed and installed on the end of an extension pipe or hose.

Mounting the reservoir too low could result in oil draining back, or overflowing the tank. Be sure to allow enough space above the reservoir to service the filter.

If the reservoir is not supplied by MAX POWER, then provide a return filter of 60 microns and a suction strainer.

The thrusters' motor case drain, must return directly to the top of the tank. With no filters check valves or other drain lines connected to it.

The reservoir must be flushed after installation.

DIRECTIONAL CONTROL VALVE

The directional control valve (DCV) must be placed between the pump and the RETRACT unit, it is recommended to locate the DCV as near to the RETRACT as possible (in an accessible and dry place).

The DCV block used must be equipped with a pressure gauge so as to check operating pressure on commissioning and for maintenance.

The block must be equipped with a pressure relief valve set to 250 bars

ELECTRICAL SYSTEM INSTALLATION

Although MAX POWER has used the best materials available, the installer should endeavour to install all electrical equipment with the view that it should be in a ventilated and dry environment at all times. Control panels mounted at helm stations must be provided with protection if the station is exposed to the weather.

All wiring must be insulated from ground and its installation executed in compliance with safety and classification standards.

CONTROL SYSTEM

CONTROL SYSTEM MAX POWER

The Retract R600 control system is all centralised in the electronic control box (or the PLC)

All numbers indicated on our diagrams must be connected 1 to 1 and 2 to 2 wire sections must be respected to the letter.

The control box command's the up down unit and hydraulic power spool valves in the correct sequence with correct timing.

There is scope for modifying sequence timing in this box but consult MAX POWER FIRST!

All Retract equipment is connected to this box (See diagram N° 9)

MAX POWER

All wires should be carefully **labelled to reduce the chance of error** and simplify checking and troubleshooting.

All wire ends for terminals should be tinned before inserting into terminal blocks.

The control system of the RETRACT requires 30 amps of stabilised 24 v dc power. The 24 volt input power is automatically transformed to produce 12 volts for the control panel use **control panel only**.

The major power consuming components of the RETRACTS electrical system (the raise/lower unit, the directional valve solenoids, and the electromagnetic clutch) are supplied with 24 volts **from the** control box.

Complimentary alarms may be added at will (over heat, low oil, etc etc)

Switching the thruster **system** on is achieved by a two-pole 32-amp circuit breaker (not supplied by Max Power), which should normally be located on the main electrical panel.

CONTROL SYSTEM PLC (NON MAX POWER SUPPLY)

If the max power control box is not used an integrated PLC can be used to replace it. If this is the case The PLC must be programmed to follow the following sequences. It will also require.

8 input channels (inductive proximity switches) 2 up 2 down 2 locked 2 unlocked.

4 output channels (switching 24v 2amps) up down motor supply, up valve, down valve, left thrust, right thrust.

R 600 PLC Sequencing

UP SEQUENCE

UP COMMAND GIVEN

1. Check locks – unlocked position detected
2. Pressure on lifting rams **up**.
3. Thruster detected up.
4. 1/2-second delay.
5. Power on locking rams **locked**
6. Lock detected locked
7. 1 second delay
8. Power off locks + Pressure off ram.

Constant alarm guard on locks and up detectors

DOWN SEQUENCE

DOWN COMMAND GIVEN

MAX POWER

1. Pressure on lifting rams **up**
2. ½ second delay.
3. Power on locking rams **unlock**
4. Locks detected unlocked
5. Pressure on lifting ram **down**
6. Thruster detected down.
7. Pressure on lifting rams off

Constant alarm guard on thruster down position detected

THRUST SEQUENCE

THRUST COMMAND GIVEN

1. Check thruster down detector.
2. Pressure on ram down.
3. ½ second delay, PROGRESIVE Pressure on thruster motor port or starboard.

Position detectors are Telemecanic normally open 3 wire = 1 pos supply 2 switching

Voltage limits	-10 58V
Load switching capacity	1.5 100mA
Voltage drop	< 4V
Leakage current	< 0.5mA
Current consumption	-

CHECKS, TESTS & ADJUSTMENTS

BEFORE LAUNCHING

IMPORTANT: Before the launch, verify that the RETRACT unit inspection top plate has been replaced (if it was removed during installation) and that all the lower flange bolts have been tightened. Torque for all these bolts is **5 kg/m**.

Filling the hydraulic circuit.

MAX POWER recommends the use of **ISO GRADE 15 to 32 hydraulic oils** for the power circuit. This mineral oil has already been used by Max Power during the run in tests and consequently the RETRACT motor and piping are already filled with this kind of oil.

CAUTION: Biodegradable and mineral (commonly used) oils are non-compatible and should not be mixed or used together. Mixing them will deteriorate certain hydraulic elements. If you intend to use a biodegradable oil, thoroughly flush the existing mineral oil from the RETRACT unit first with the appropriate oil.

Before carrying out the below test we recommend to disconnect the wire at terminal N° 32 in the control box.
Or if PLC, disable thrust valve!

MAX POWER

- Check all fittings for tightness and leaks.
- The transmission is already filled with oil at the time of delivery.
- Max Power uses HYPIOD HD 80W/90 oil in the transmission; therefore, fill the transmission lube oil header tank with similar grade oil. The function of this lubricant tank is to ensure a constant pressure, as well as a visual control of the oil-level. The tank should be filled to the $\frac{3}{4}$ level. Purge air in tube before fitting the pipe to the RETRACT.
Performing the UP / DOWN tests (standard joystick control panel).
- Check UP / DOWN operation.
- This unit has a second function, in that it blocks the turbine in the down position when thrust is applied.
Move joystick to port or starboard and check that the up/down hydraulic pump is pushing the turbine down.

AFTER LAUNCHING

- Check for water leaks.
- Switch on the system power at the breaker and repeat the UP / DOWN tests.
- Execute a few short left and right manoeuvres to fill the circuits and thereby purge the system of all air. After each manoeuvre, check and fill if necessary, the hydraulic tank. Repeat until the level remains stable.

Warning: All hydraulic systems develop very high pressures. Failure of piping, connections etc that have been improperly installed will most likely happen on start up. Stay clear of these components. Wear eye protection, and be aware that high-pressure oil can cause major skin damage.

- Check the thrust direction:
- With the Joystick to the left (port), the vessel should move to port and conversely. If the direction is not correct, inverse to connectors on the hydraulic distributor.

Once all the above tests have checked out correctly, you may now carry out the directional control valve (DCV) adjustments and the thrust tests.

OPERATION AND USE

Operating Procedure If using standard max power control panel

Switch on the system power breaker (main equipment panel).

On the control panel:

- Turn, the red button switch to the right. The red lamp will light, indicating that power is available, and the turbine is in the raised position.
- Pull the joystick towards your self (aft or down), the red light will extinguish, the alarm buzzer will sound until the green light illuminates. The unit is ready for use when the green light is lit and the buzzer is silent.
- Move the joystick to the left (port), the vessel will move to the port and conversely.

MAX POWER

Use the thruster as required. If the alarm buzzer sounds and the green light are still on during operation, stop the thruster immediately. This alarm indicates that a problem has occurred on one of the auxiliary alarms.

When finished reverse the above operation: move the joystick away from yourself (forward or up), the green light will extinguish, the alarm sounds until the red light illuminates indicating that the RETRACT is fully retracted. It is now safe to advance at normal cruising speeds.

CAUTION: Never leave the RETRACT in lowered position when not in use. The RETRACT must be in up position (retracted) when sailing.

The RETRACT is designed to be used in harbour when manoeuvring at low speed (below 3 knots).

Switch off the system power breaker.

TROUBLESHOOTING GUIDE

PROBLEM: Thrust stops almost immediately after it has been applied. The alarm buzzer comes on and the green light turns off.

PROBABLE CAUSE 1 – The Raise/lower Electro-pump unit is not working correctly.

REMEDY: Check that the Raise/lower unit has 24-vdc powers to the motor. Check that the pump operates in down position before the thruster starts.

PROBABLE CAUSE 2 - position switches out of adjustment.

REMEDY: Readjust the position switches by loosening its securing nut and readjusting it closer to the actuator.

PROBLEM: The thruster seems to be developing less thrust.

SECONDARY CAUSE: Low oil pressure.

REMEDY: Check pressure. Consult hydraulic technician

THIRD CAUSE: Propeller problem (plastic bag, rope, etc...)

PROBLEM: The turbine retracts, but the alarm does not stop or the red light does not illuminate.

PROBABLE CAUSE: An object such as a line, or other flotsam is caught between the closing plate and the hull.

REMEDY: Raise and lower the unit a few times to see if the object clears. If it does not, try to remove the object manually.

WARNING NEVER put **your hand into the opening of the hull.**

PROBLEM: The RETRACT will not open.

PROBABLE CAUSE: No power (24 vdc) to the Raise/lower unit.

REMEDY: Check the 20 amps or 15-amp fuse breaker in the control box,
Check that wire number 5 has power,
Check that power is available to the unit, by checking the voltage on wires
Check oil in the reservoir of R/L unit
Check joystick operation.

MAX POWER

MAINTENANCE OF THE RETRACT

Regular checks

1. Lower and raise several times every month
2. Transmission lubricating oil reservoir level.
3. Hydraulic power oil reservoir level.
4. Hydraulic hoses for chaffing and leaks.

Control panels, like all external equipment, should be protected from the sun and weather when not in use. Clean with a soft cloth and mild detergent solution.

Yearly checks boat ashore.

1. Clean the turbine, gearbox and the propellers with a sponge and detergent soap. It is also advisable to remove the top cover plate and clean the interior of the caisson and rinse well the articulated joints.
IMPORTANT: If the vessel will remain out of the water for some time, for example: dry storage for the winter, the top cover plate must be removed and the RETRACT mechanism must be thoroughly rinsed with fresh water, especially the articulated joints. Do not operate below 0° C.
2. Replace all anodes & Check the underwater unit for loses bolts.
3. Change transmission oil, if you find water in the drive leg oil check seals.
4. Remove the propellers and check oil seals replace if necessary.
5. Inspect and repair the hull closing plate gasket for deterioration or missing pieces. Check and tighten if necessary, the plate fixation bolts.
6. Apply antifouling paint to the closing plate on the outside, on the edges and if desired to the plates inner surface. If you find growth on the unit, this is because your closing plate gasket allows light to enter the enclosure.
CAUTION: Do not use antifouling or other copper based paints on the RETRACT turbine.
7. The transmission oil must be changed each year. Extracting the sump plug screw can do this. Never let the oil level in the lube tank descend below the level of the ships waterline.
8. Check the entire hydraulic system hoses and connections for possible chaffing and leaks.
9. Every two years, drain the entire hydraulic oil system. Clean and replace filters.

5 Years

1. Complete removal of unit and return to factory.
Replacement of all submerged flexible hoses.
Replace all oil seals and check for bearing wear.
Unit striped and re corrosion treated / painted.
Replacement of all articulation bushes.
2. Service of complete hydraulic oil system included pump, distributor, etc...

MAX POWER

IMPORTANT

**PROJECT MANAGER'S
TEST RESULTS FORM**

**To be filled out and
Faxed to MAX POWER**

MAX POWER

TEST RESULT FORM (part 1)

This form must be filled out and faxed to MAX POWER within a week after launching so that the MAX POWER standard warranty is validated.

MAX POWER
Via Philips 5, 20900 Monza, Italy

Tel : (39) 039 200 1973-936
Fax: (39) 039 2004299

From:

.....

.....

.....

.....

.....

.....

Date:

REFERENCE: S __ .R6__ . ____

- 10. Shipyard that installed the RETRACT:
- 11. Name of the Project Manager:
- 12. Name of the Vessel:
- 13. Type & Make of the Vessel:
- 14. Date of launching:

Please answer by YES or NO the following questions concerning the installation:

		YES	NO
1	Is the RETRACT mounted parallel with the bottom of the hull?		
2	Is there enough room for general maintenance of the RETRACT and its auxiliary equipment?		
3	Does the closing plate rest upon a gasket?		
4	Is the adjustment of the closing plate done in such a way that no light is allowed to enter?		
5	Are the anodes correctly fitted to the closing plate supports?		
7	Is the RETRACT unit glued to the mounting base?		
9	Is the pressure relief valve set to 250 bar		
10	Are all-electrical wires numbered at each end and with their terminals tinned?		
11	Is the electrical supply to the remote control box constant and stable?		

MAX POWER

When all the tests have been completed as per the manual, please record the following measurements where applicable.

With the engine(s) running, thruster in the down position, but not running:

1. Record the voltage at the remote control box: Volts

With the engine(s) running and the thruster running (either direction):

1. Record the voltage at the remote control box: Volts
2. Record the hydraulic pressure: slow speed Bars
3. Record the hydraulic pressure: full speed Bars
4. Record the hydraulic flow: slow speed LPM
5. Record the hydraulic flow: full speed LPM
6. Record the hydraulic pressure on the up/ down unit: Bars
8. If ramping used please give approximate time from 0 to 250 bars. In Seconds

Other comments:

DATE OF TESTS: LOCATION :

PERSON RESPONSIBLE :

SIGNATURE :

MAX POWER

TECHNICAL DATA SHEET R600 (100HP)

OILS – LUBRIFICATION

Drive leg	
Litres	4l
Type	EP 90 Gear oil
Recommended grease	Molycote HV silicone

OIL – HYDRAULIC

Flow	200 lpm
Maximum Pressure	250 bar
Oil type	Hydraulic
Viscosity	46 csst

UNIT SPECIFICATIONS

Maximum Power	75kw
Total weight unit	300kg
Propellor diameter	600mm
Propellor thrust	1000kg

HYDRAULIC RAM SPECIFICATIONS

Maximum Pressure	70 bar
Maximum flow	3 lpm

ELECTRIC RAM SPECIFICATIONS

Voltage	24V
Power consumption in Amps	10 A each

PROXIMITY SWITCHES

Voltage limits	10 58V
Load switching capacity	1.5 100mA
Voltage drop	≤4V
Leakage current	≤0.5mA

MAX POWER

IF IN DOUBT PLEASE ASK

R600 110 / 80 hp

PROPELLER POWER MAX 80 KW
 THRUST 1100KG
 HYDRAULIC PRESSURE 250 BAR
 HYDRAULIC FLOW 200 LPM

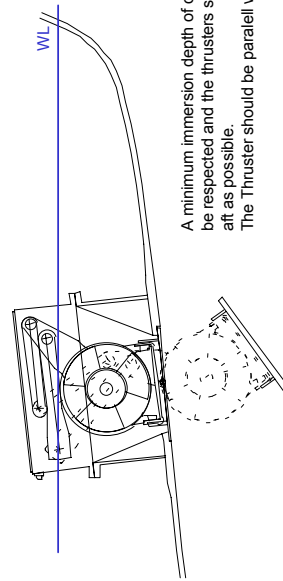
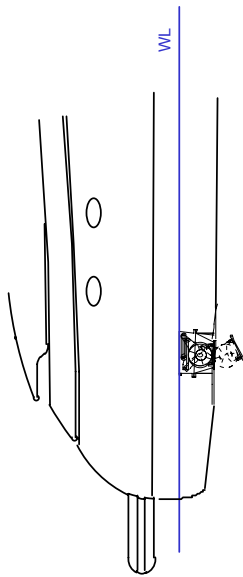

A minimum immersion depth of one full turbine diameter should be respected and the thrusters should be as far forward or aft as possible.
 The Thruster should be parallel with the bottom of the hull

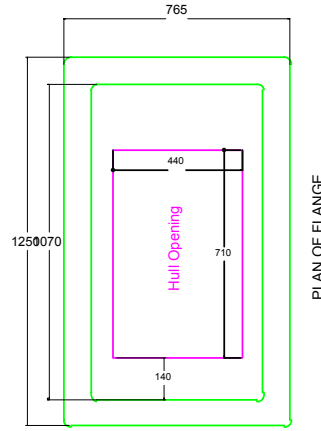
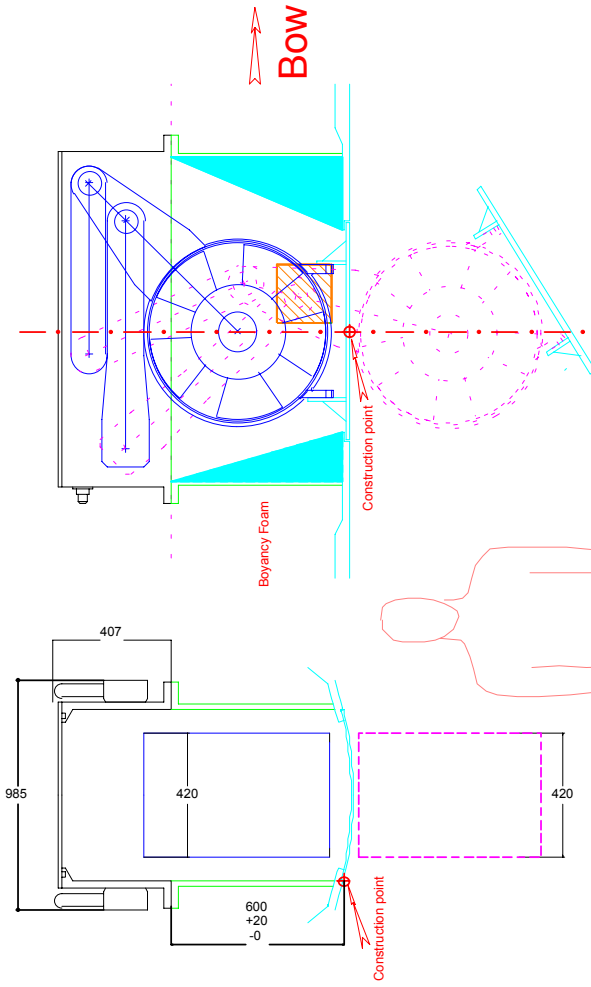

DIMENSIONS		MM
SCALE	DRN	NPTS
DATE	DATE	YGT
	12/02/01	

REF

Do not build from these drawings use those supplied with the unit .

TITLE		100 HP RETRACT (R600)
NO:	TR60001	ISSUE: 4

MAX POWER

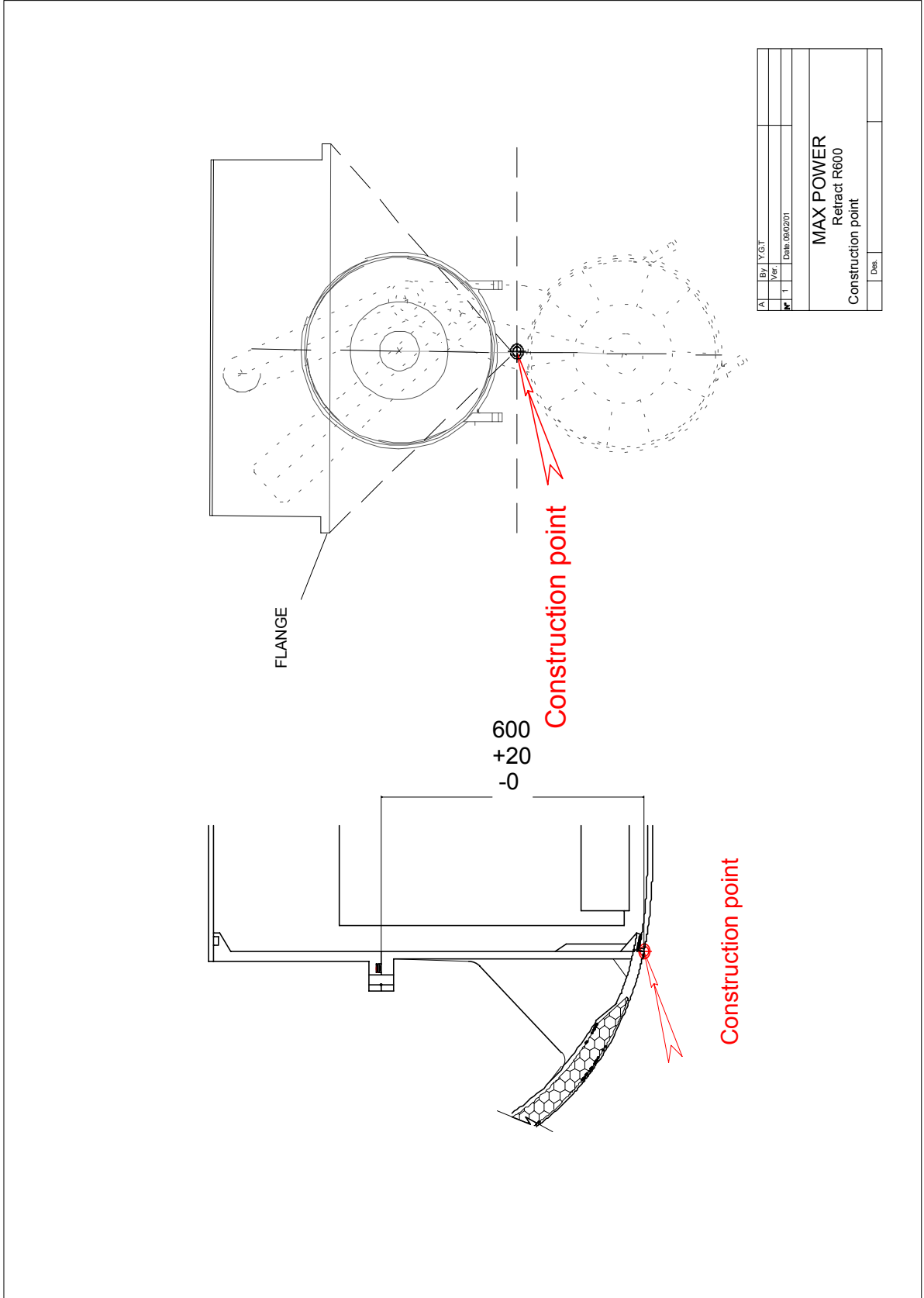

MAX POWER

Positioning

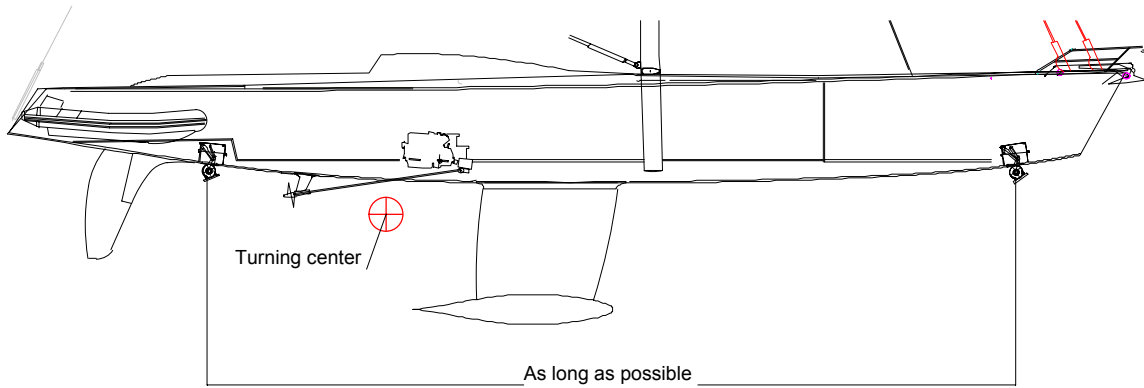

The Retract must be parallel with the bottom of the hull

A minimum immersion depth of one full turbine diameter should be respected and the thrusters should be as far forward or aft as possible.

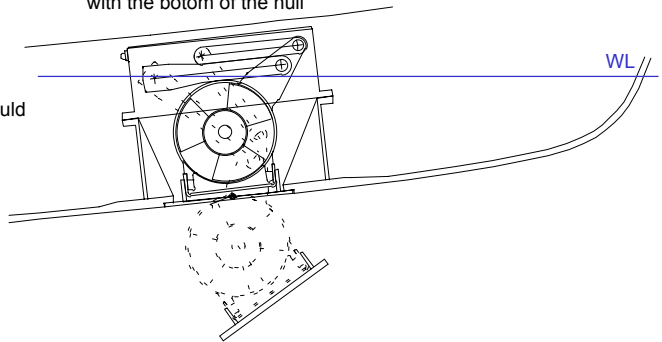

Hull Opening

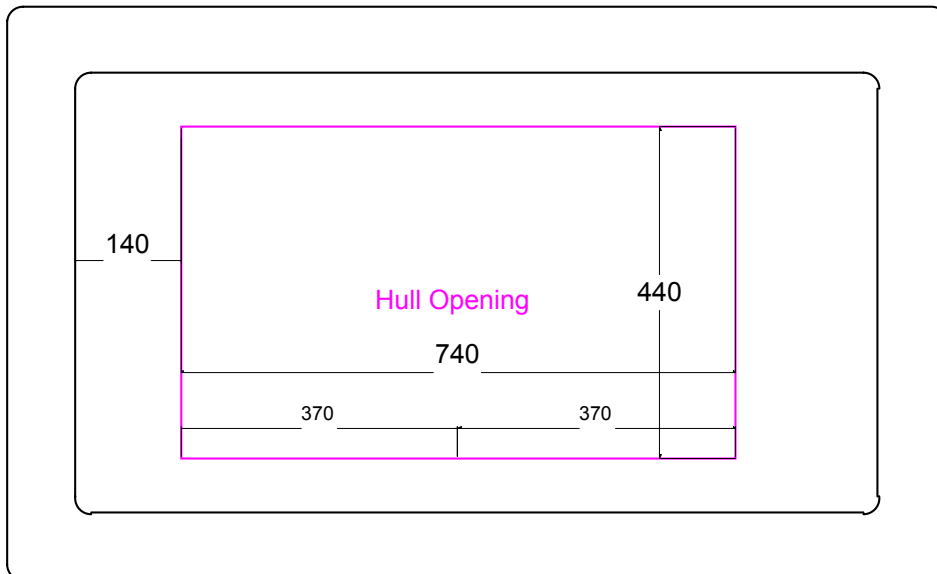

→
Bow

MAX POWER

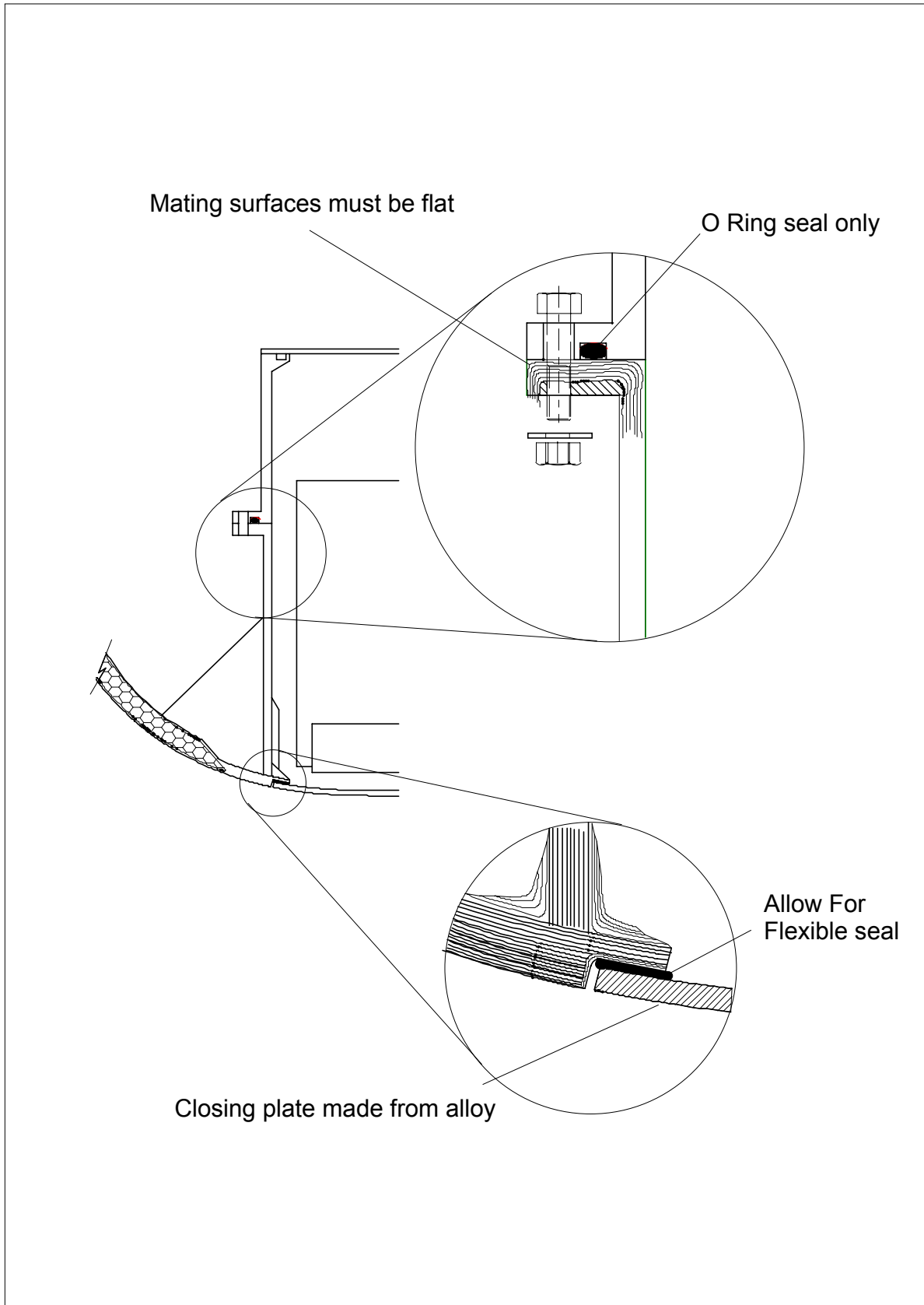

MAX POWER

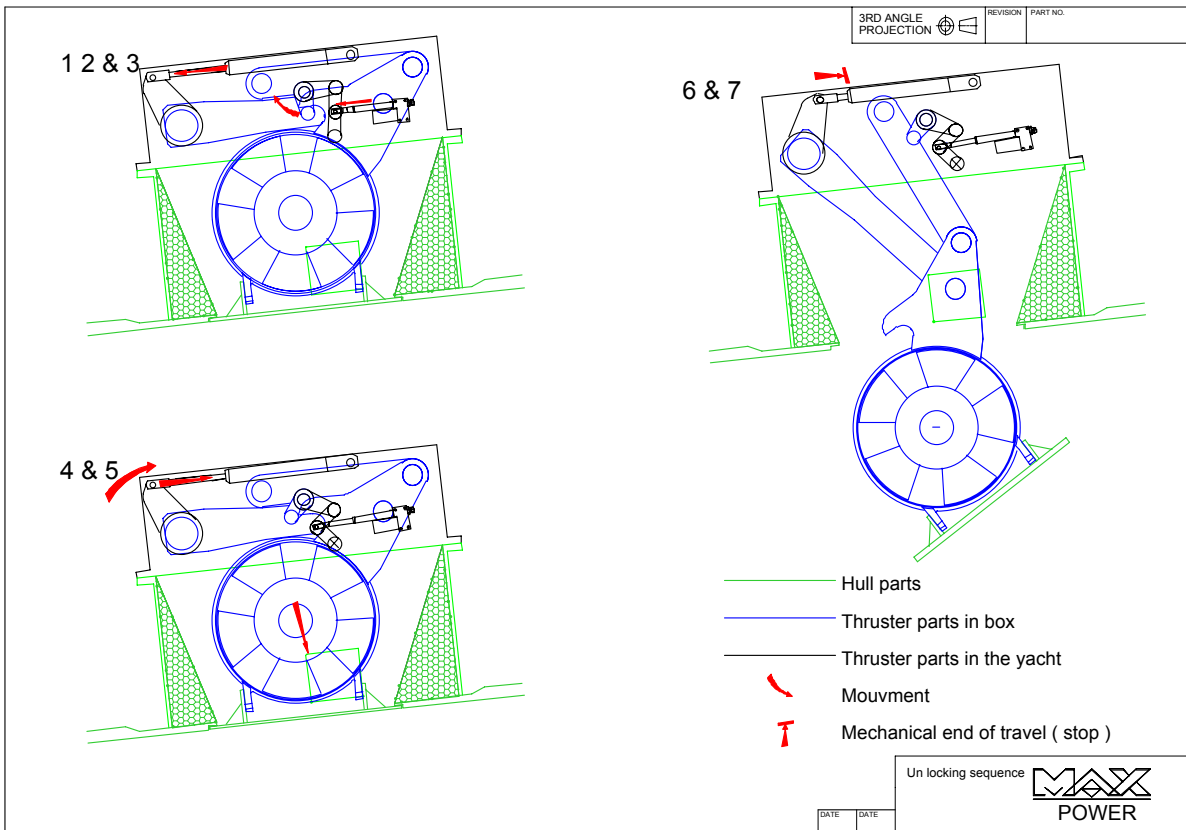
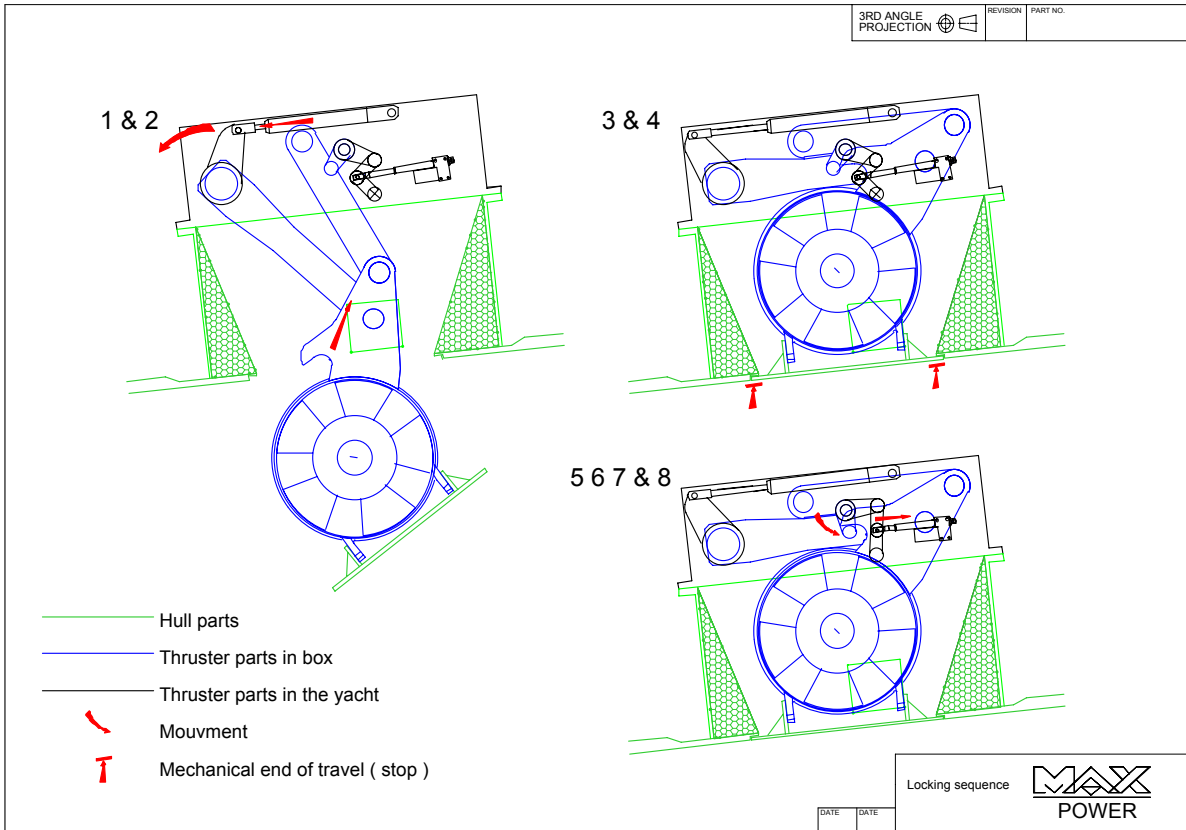

MAX POWER

To obtain a perfect hull plate fit follow these instructions

3RD ANGLE PROJECTION
REVISION PART NO.

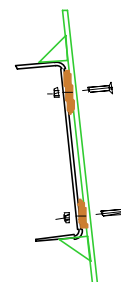
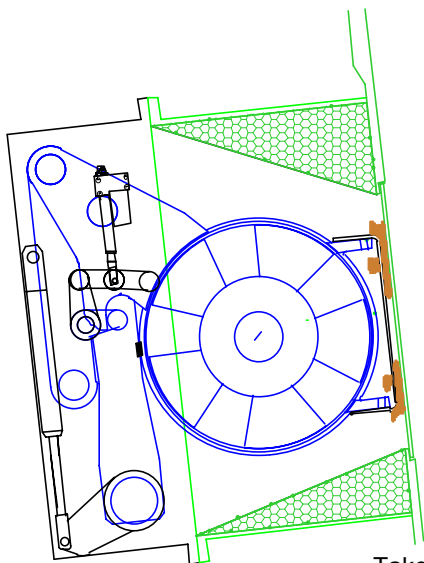

Fitting the hull plate

DATE DATE

Take the finished and formed hull plate and place four piles of beading compound on it and push the plate into place(3).

Hold the plate in place until total curing of the compound. Then lower the thruster and remove the bracket hull plate assembly now glued together.

Reinforce the bond between plate and bracket using mechanical fasteners as per construction technology.

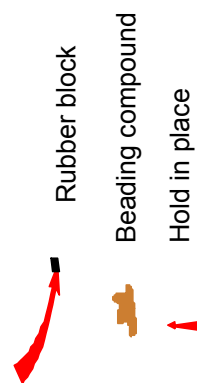
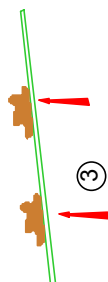
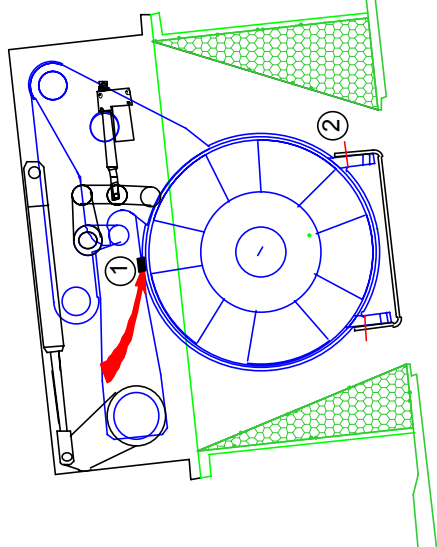

With thruster securely bolted down on its flange, install the hull plate bracket on the thrusters mounting points. Be sure that the locking point positioning blocks are in place (1). Score the position so as to be able to re fit it in exactly the correct place (2).

MAX POWER

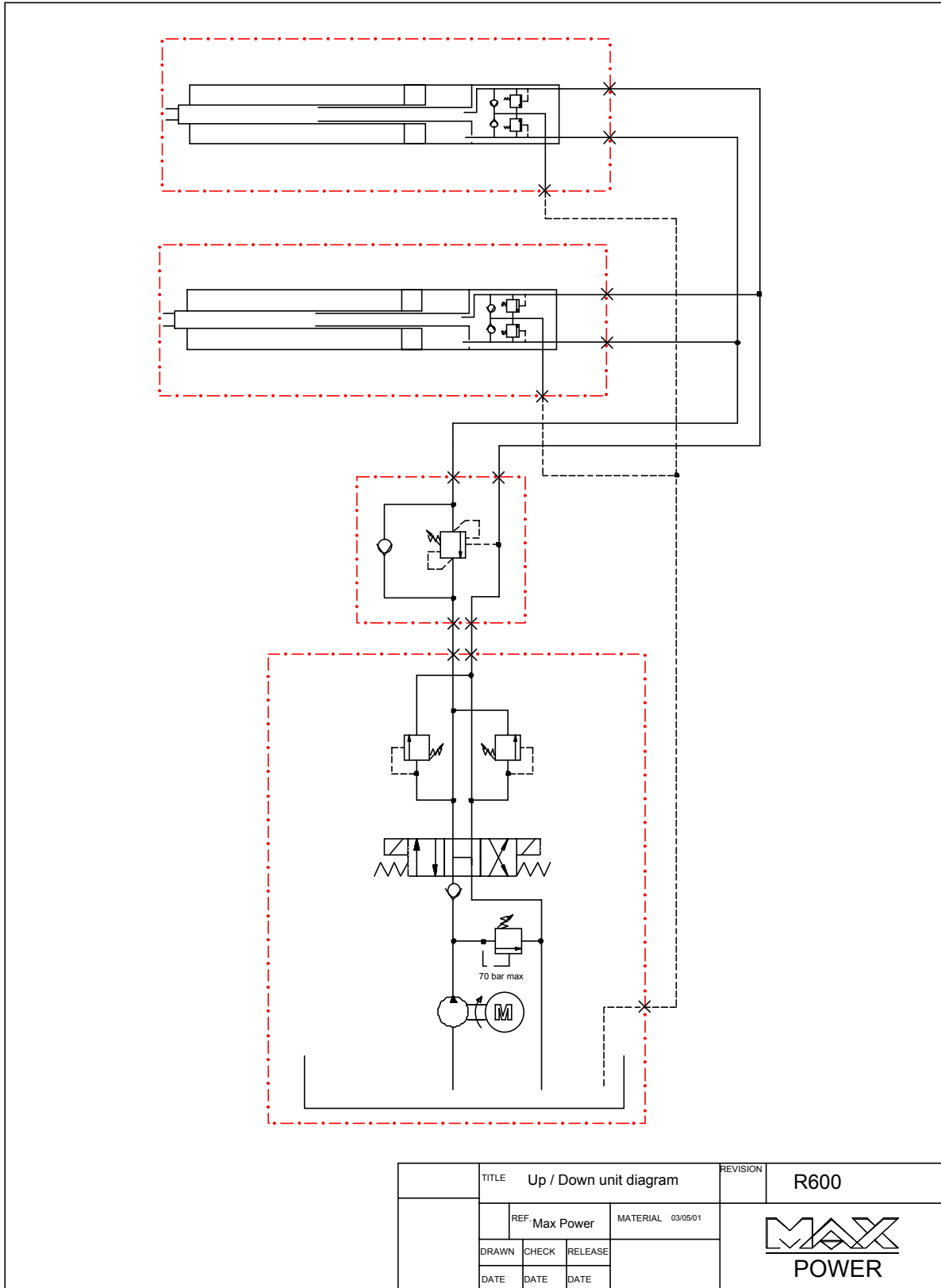

MAX POWER

R600

The hydraulic circuit should be fitted by a hydraulic technician.

The hydraulic hoses should be crimp connected, and pressure tested.

HYDRAULIC HOSES:  (as recommended for Max Power equipment)

PPD: Supply feeder hose from pump to hydraulic directional valve; High pressure (HP) 1 , 1/4'

DAR: Supply from hydraulic directional valve to the retract; HP thermo plastic hose 1 , 1/4'

DBR: Supply from hydraulic directional valve to the retract; HP thermo plastic hose 1 , 1/4'

RD: Motor drain from retract directly to oil tank; LP hose minimum 1/2'

LV: Synthetic 100 bar pressure Hoses 1/4'

LD: Synthetic 100 bar pressure Hoses 1/4'

CONNECTIONS / FITTINGS:  (as supplied on Max Power equipment)

A1 : Male 1, 5/16" jic 37° B1 : Male 1, 5/16" jic 37°
 D1 : Male 3/4" jic 37°

LA / LB / LD : Male 1/16" jic 37° VA / VB / VD : Male 1/16" jic 37°

CV : Male 1/16" jic 37°

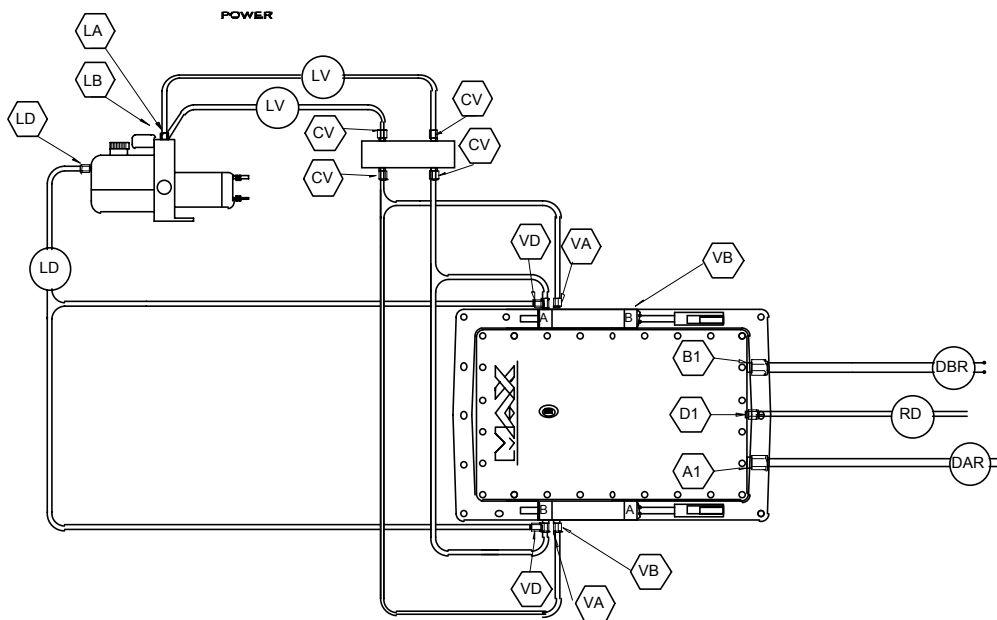

TITLE Hydraulic fittings		REVISION	PART NO.
REF Max Power	MATERIAL		

Introduction

The purpose of this document is to set out the terms of warranty cover offered in relation to products purchased by the End User from Max Power or its approved network of resellers.

1. Definitions

- **Authorized Repair Number:** The number given by Max Power on reporting a fault with your thruster
- **Dealer:** An authorized Max Power sales centre
- **End User:** The boat supplied with supplied equipment and the owner thereof
- **Installer:** The authorized centre responsible for the installation of your thruster
- **Manufacturer:** supplier of the equipment under warranty
- **Pleasure Craft:** Vessels used for owner's personal use that have no commercial use (i.e Charter boats or work boats)
- **Resellers:** Max Power approved distributors and dealers
- **Serial Number:** Number in upper right hand corner of Warranty document
- **Supplier:** The manufacturer (Max Power)
- **Warranty:** The terms and conditions that are covered by the manufacturer

2. Period of Coverage

The equipment manufactured by the Supplier is guaranteed to be free from defective workmanship, components and materials under normal usage conditions for a period of three (3) years from the date of purchase by the End User. This warranty is transferable to subsequent owners of this equipment during the period of coverage.

3. Warranty Registration

Register your purchase now at www.max-power.com. (NB. proof of purchase must be kept throughout the warranty period)

4. Warranty Terms

If the material is used for anything other than for pleasure craft, the guarantee is limited to a six-month period.

Year 1: All factory testing, diagnosis, repairs and replacements are performed at no charge to the End User; All parts and up to two hours of labour are covered for repairs and replacements conducted in the field.

Year 2 & 3: All factory testing, diagnosis, repairs and replacements are performed at no charge to the End User.

This excludes any damage or faults occurring from normal wear and tear on the following items: engine, oil seals, relay contacts (If warranty is registered within the 3 month period following installation)

5. Warranty Exclusions

- Damage due to modifications or installation contrary to published specifications
- Cost of hauling the boat
- Damage due to repairs performed by an unauthorized service centre
- Damage due to lack of normal maintenance services
- Damage due to water
- Parts replaced due to normal wear and tear
- Repairs performed without knowledge of manufacturer (please contact dealer to receive Repair Authorization Number)
- Tampering of equipment by the End User
- Cost of travel to and from the job site
- Cost of economic loss, including injury to any person, damage to property, loss of income or profit, communication, lodging, inconvenience
- Consequential damage due to failure, including those arising from collision with other vessels or objects

6. Procedural Guidelines

PLEASE VIEW THE TROUBLE SHOOTING LIST ON THE MANUAL OF YOUR PRODUCT TO ASCERTAIN OR SOLVE ORIGIN OF PROBLEM PRIOR TO CONTACTING THE DEALER/INSTALLER

1. Contact your dealer/installer to report the problem.
 - If you do not know who this is, contact the nearest Max Power distributor
 - If you are in foreign waters, please contact the nearest Max Power distributor
2. Ensure you have your serial number and model number to hand (top right hand corner of warranty)
3. Dealer/Installer will come to site to decipher the cause of the fault
4. If the cause of fault is due to a manufacturing problem the dealer will contact Max Power to receive Repair Authorization Number.
5. If the problem is due to an installation error please contact your installer.

IF POSSIBLE: PLEASE TAKE PHOTOGRAPHS OF THE THRUSTER TO SHOW PROBLEM

7. Service Centers

Please go online www.max-power.com to find the authorized service station of your area.

The warranty as outlined above is only applicable to Max Power manufactured thrusters and optional equipment as used in marine pleasure industry. The supplier holds the exclusive right to test the product and determine whether it is defective